

Combining LED exit illumination with reliable LED lamp heads, this attractive low-profile design offers maintenance-free, long life dependable service. Easily mounts above doors and in restricted spaces to fit any application.

FEATURES

- LED exit combo where each of the heads contain 8 long lasting, efficient, ultra-bright white LEDs using 1.1W per head
- Easy to install, snap-together design
- Rugged, injection-molded UL94 5VA flame-retardant, high-temperature thermoplastic housing
- Remote capable - up to 2 MLED remote heads
- Universal style - includes 2 faceplates, a backplate and mounting canopy
- Charge rate/power "ON" LED indicator light with test button
- Low voltage disconnect eliminates deep discharge
- Maintenance-free NiCad battery
- Ceiling or wall mount
- UL Listed 90 minute emergency run time, 24 hour recharge time
- Constant, uniform illumination by long-life, high intensity, red or green LEDs
- Fully-illuminated 6" characters with 3/4" stroke
- Optional Guardian Self-test/Self-diagnostics (G2) available
- Field-selectable directional chevron knockouts
- 120/277VAC Dual primary, 60Hz input
- Standard finishes: Black or White
- Suitable for Damp Locations
- California Energy Commission (CEC) compliant

Model: _____ Date: _____
 Accessories: _____
 Job Name: _____ Type: _____



WARRANTY

Any component that fails due to a manufacturing defect is guaranteed for five years with a separate five year prorated warranty on the battery. The warranty does not cover physical damage, abuse or instances of uncontrollable natural forces. See the full Exitronix warranty document for detailed information.

ORDERING INFORMATION Example: VLED-U-WH-EL90-G2

Series	Style	Finish	Type	Options (Factory Installed)	Accessories ⁴ (Field Installed)
VLED = Red	1 = Single Face	BL = Black	EL90 = LED Lamps	G2 = Self-test/Self-diagnostics	ER1-KIT ³ = 1' Pendant Mount Kit
GVLED = Green	U ¹ = Universal	WH = White		R ² = Remote Capability	ER2-KIT ³ = 2' Pendant Mount Kit
Notes					VEPA = Pendant Adapter
¹ Universal includes 2nd exit face and backplate					WG-5 = Wire Guard (Back Mount)
² For use with single or double MLED remote lamps only					XG-EL90 = Poly Guard (Back Mount)
³ Requires VEPA option					MLED1 ⁵ = Single Remote Lamp
⁴ Order as separate line item					MLED2 ⁵ = Double Remote Lamp
⁵ See page 2 for ordering information					

CONSTRUCTION

The VLED-EL90 series is constructed of a precision-molded housing utilizing 5VA flame-retardant, corrosion-proof, UV-stable thermoplastic. N.F.P.A. approved field-selectable chevrons. Units resist denting, peeling and scratching.

ILLUMINATION

Fully illuminated 6" letters with 3/4" stroke is achieved with high output, long lasting green or red LEDs. An exclusive color-matched diffuser eliminates hot spots and striations, providing optimal light output.

EMERGENCY LIGHTS

6V, 1.1W high-intensity LED lamp heads.

ELECTRICAL

Input

Dual-voltage input 120 or 277VAC @ 60Hz.

Nickel Cadmium Battery – NiCad

Exitronix nickel cadmium batteries are maintenance-free with a life expectancy of 15 years. Nickel cadmium batteries offer high discharge rates and continue to perform in a vast temperature range from 0°C to 40°C (32°F to 104°F).

Emergency

The VLED-EL90 series exit will operate for a minimum of 90 minutes during a loss of power with a 24 hour maximum recharge time for the battery.

Brownout Circuit (G2 only)

Brownout circuit monitors the line voltage, as the line voltage sags and can no longer illuminate the exit sign to meet UL 924 visibility test, the emergency circuit will turn on to supply a portion or all the power to illuminate the sign for a minimum of 90 min until the line voltage is restored.

Low Voltage Disconnect (G2 only)

Low Voltage Disconnect (LVD) measures the battery terminal voltage. The LVD continuously monitors the battery terminal voltage and if it should fall below a preset voltage threshold, the LVD will disconnect the load. When the battery is recharging and voltage is raised above another preset voltage threshold, the load is automatically reconnected.

Solid-State Transfer

The circuit features solid-state switching for emergency lamps, eliminating concerns of damaged contact or mechanical failures associated with relays. The switching circuit detects a loss of line voltage and automatically switches to emergency mode.

Test Button

The test button is easy to locate and provides manual verification of the transfer circuit and emergency lamps.

INSTALLATION

Simple snap-together universal design allows for faceplate and back plate to be fully interchangeable. Mounting canopy is supplied with all signs and snaps into enclosure with two positive locking tabs.

Damp Location Rated

Damp Location Rated fixture that is normally or periodically subject to condensation of moisture in, on or adjacent to, and includes partially protected locations.

OPTIONS

Guardian Self-Test/Self-Diagnostics (Option: G2)

The Guardian bi-color circuit is factory preset; without any field adjustments needed. It continuously monitors the performance condition of the AC power, battery supply, and charging circuitry.

The intent of this option is to provide visual signaling to identify fault at the Exit. Fault indicators are as follow:

Battery Disconnection: (Steady RED)

Battery Recharge Failure: (Flashing RED)

Battery Failure: (RED Blinking '2' times)

LED Failure: (RED Blinking '3' times)

Remote Capable (Option: R)

The R option provides this unit with an additional 3W of remote capacity for use with (2) MLED or (1) 2MLED remote lamps.

CONFORMANCE TO CODES & STANDARDS

The VLED-EL90 Series is UL listed and meets or exceeds the following: UL 924, CEC, NEC requirements and NFPA 101.

REMOTE LAMPS (Order Separately)

FEATURES

- Each lamp contains 8 long lasting, efficient ultra-bright white LEDs
- For use with VLED-EL90 or CLED combo units only
- Wet Location option available



Single Lamp with
Weatherproof (WP) Option



Double Lamp with
No Options

REMOTE ORDERING INFORMATION

Example: MLED1-W-G2

Series ¹	Finish	Options
MLED1 = Single Remote Lamp	B = Black	G2 ² = Self-test/Self-diagnostics
MLED2 = Double Remote Lamp	G = Gray	WP ³ = Weatherproof Applications
	W = White	

Notes

¹ Order remote lamps as separate line item

² Unit powering remote lamp head must also have G2 option

³ WP option available in Black or Gray finish only

SPACING GUIDES

Using multiple units mounted at a typical 8' delivers 18' center-to-center spacing on a 3' wide egress path.

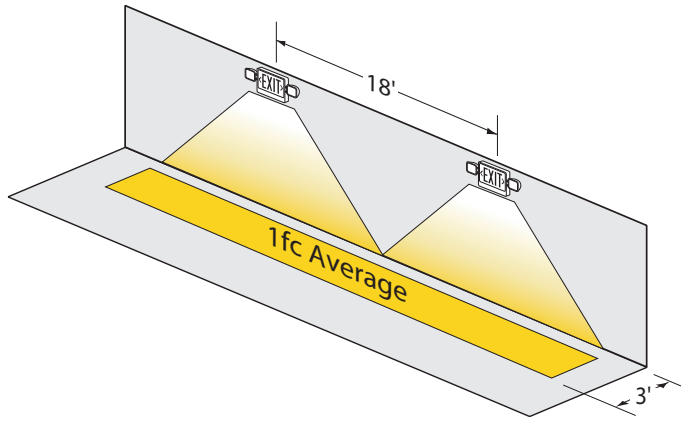

Using multiple units mounted at a typical 8' delivers 14' center-to-center spacing on a 6' wide egress path.

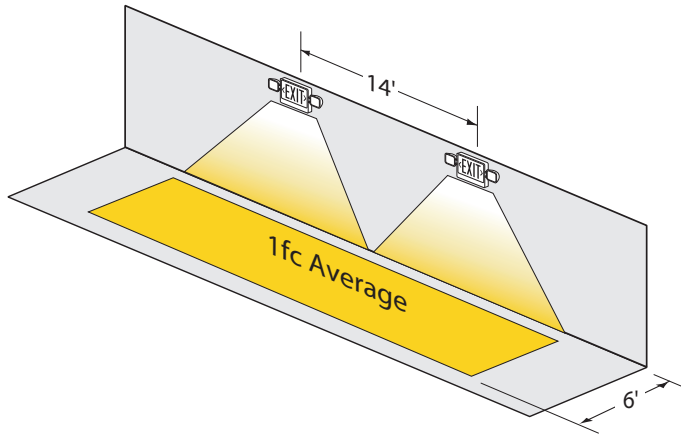

DIMENSIONS

