

The Prescott 3 is a freestanding, three phase, on-line, double conversion Uninterruptible Power Supply (UPS) utilizing advanced DSP/PWM technology to deliver conditioned, uninterrupted AC power. Each system consists of a solid-state inverter, rectifier/battery charger, static bypass switch, internal maintenance bypass switch, sealed maintenance-free battery plant, and a microprocessor-based status and control system with advanced diagnostics and monitoring.

Model: _____ Date: _____
 Accessories: _____
 Job Name: _____ Type: _____

- Input Voltage:** 208, 480, 208Y/120 or 480Y/277 VAC
- Input Voltage Range:** +10% -15%
- Output Voltage:** 208Y/120 or 480Y/277 VAC
- Output Voltage Regulation:** ±2% for all loads and battery discharge mode
- Output Frequency Range:** 60 Hz, ±1%
- Output Wave Form:** Sine-wave <5% @ 100% linear load
- Crest Factor:** 2.5:1 typical
- Input Protection:** Input Main Circuit Breaker
- Output Protection:** Output Main Circuit Breaker
- Surge Protection:** The unit will protect itself and the load against surges defined in ANSI/IEEE C62.45 category A/B
- Battery:** Sealed maintenance-free (AGM) lead calcium
- Recharge Current:** 10 Times discharge
- External Battery:** Provision for hardware connection of external battery cabinets or DC source
- Efficiency:** ≥92% at 100% linear load
- Audible Noise:** <45dBA
- Listing:** Conforms to UL 924 and 1778
- Operating Temperature:** 0° to 40°C (32° to 104°F)
- Storage Temperature:** -20° to 60°C (-4° to 140°F)
- Humidity:** 0 - 95%, Non-condensing



APPLICATIONS

- Data centers and IT infrastructure
- Industrial and manufacturing environments
- Water and wastewater facilities
- Transportation and infrastructure
- Energy and utility sectors
- Telecommunications systems
- Security and life safety systems
- Storm shelter backup power applications



ORDERING INFORMATION Example: PSCT3-15-208-208Y/120-90

Series	Power Rating	Voltage ¹ (Input-Output)	Run Time ⁵	Factory Installed Accessories (Order as separate line item)
PSCT3	15 = 15kVA/12KW	208-208Y/120	5 = 5 Min (Std)	ECM120/# ² = 120V Environmental Control Module / Qty
	30 = 30kVA/24KW	208-480Y/277	10 = 10 Min	ECM277/# ² = 277V Environmental Control Module / Qty
	50 = 50kVA/40KW	480-208Y/120	15 = 15 Min	NOF/V/# = Normally OFF Output Circuit / Voltage / Qty
	75 = 75kVA/60KW	480-480Y/277	20 = 20 Min	NOH/V/# = Normally OFF "Hold ON" / Voltage / Qty
	100 = 100kVA/80KW	208Y/120-208Y/120	25 = 25 Min	OCB/V/#/A ⁴ = Output Circuit Breakers / Voltage / Qty / Amps
	125 = 125kVA/100KW	208Y/120-480Y-277	30 = 30 Min	EPO = Emergency Power Off
		480Y/277-208Y/120	45 = 45 Min	RP = Remote Indicator Panel
		480Y/277-480Y/277	60 = 60 Min	SNMP = SNMP Card
			90 = 90 Min	FCON = Form C Contacts
			120 = 120 Min	SRB = Seismic Rated Brackets
		180 = 180 Min	EMB ⁴ = External Maintenance Bypass Switch	
		240 = 240 Min		
				Service Options (Order as separate line item)
				EBW# = Extended Battery Warranty (# - Specify Number of Years)
				EW = Extended Warranty
				OST ³ = Onsite Start-Up
				SC = Service Contract

Notes

- ¹ Consult factory for other voltages, may effect weight, size and number of cabinets
- ² One ECM is used per switching device or circuit
- ³ Includes one additional year of warranty on unit, consult factory
- ⁴ OCB and EMB options cannot be combined
- ⁵ Consult factory for other run times

See [Page 4](#) for Accessory Details

POWER RATING

15kVA to 125kVA, three phase output unit uses the latest technology to provide the most advanced performance and reliability features.

INPUT

208, 480, 208Y/120 or 480Y/277 VAC input.

AC Input Characteristics:

- Input Frequency: 60 Hz
- Power walk-in: 0 to 100% over a 10-second period.
- Magnetizing Inrush Current: Less than nominal input current for less than one cycle.
- Input Surge Protection: The Prescott 3 is equipped with a standard input filter assembly that will withstand surges per IEEE 587-1980/ANSI C62.41

OUTPUT

208Y/120 or 480Y/277 VAC output.

AC Output Characteristics:

- Voltage Regulation: +2.9% for no-load to full load battery discharge mode.
- Frequency: 60 Hz (+ 0.1Hz when free running).
- Voltage Distortion: Maximum 5% total (THD) @ 100% linear loads.
- Voltage Transient (Step Load) Response:
 - +/- 5% for 50% step load change
 - +/- 8% for 100% step load change
 - +/- 3% for loss or return of AC input power or manual transfer at full load
- Voltage Recovery Time: Return to within 3% of nominal value within 50 milliseconds.
- Non-Linear Load Capability: Output voltage total harmonic distortion is less than 8% when connected to a 100% non-linear load with a crest factor not to exceed 2.5%.
- Slew Rate: 1 Hz/second maximum
- Power Factor: Unity power factor.
- Inverter Overload Capability:
 - 125% of rated load for 1 minute
 - 145% of rated load for 10 seconds
- Bypass Overload Capability: > 200% for one cycle; > 150% for 30 seconds

LOADS

- Pure sine wave output compatible with sensitive electronic and mechanical equipment
- Uninterrupted power provides continuous AC output to critical loads for the entire runtime
- Supports IT equipment, communication systems, building control systems, and other critical infrastructure
- Compatible with switch-mode power supplies, control electronics, and most electronic equipment
- Operates servers, networking equipment, security systems, HVAC fans, storm shelter louvers, industrial controls, and other sensitive electronic or mechanical loads, etc.

BATTERIES

The Prescott 3 module employs a valve regulated, sealed, lead calcium, heavy-duty, industrial battery. This battery system is designed for auxiliary power service. The primary battery is furnished with an impact resistant plastic case and housed in matching battery cabinet (units 18kVA or under are self contained).

- Protection against deep discharge and self-discharge: The Prescott 3 is equipped to protect the battery against deep discharge depending on discharge conditions, with isolation of the battery by a circuit breaker. In particular, a monitoring device will adjust the battery shutdown voltage as a function of a discharge coefficient in order to avoid excessive discharge.
- Battery self-test: The battery monitoring system is to perform the following automatic functions:
 - 1. Battery circuit check
- Sealed, maintenance-free, lead calcium (AGM) batteries
- 10 year prorated warranty
- Guardian Smart Battery Monitoring System is TEMPERATURE COMPENSATED maintaining maximum runtime and battery life
- Microprocessor controlled recharge and overcharge protection is standard

CODES

- City of Chicago and New York approved
- Complies with the Buy American Act (Level 3) and Build America Buy America requirements
- The Prescott 3 will meet the requirements of the following standards:
 - IEEE 587-1980/ANSI C62.41 1980 Standards for Surge Withstand Ability
 - FCC rules and regulations of Part 15, Subpart J, Class A
 - Meets UL 1778, UL 924, Standards for UPS Equipment
 - NEMA PE 1 (National Electrical Manufacturers Association) - Lighting Inverter Systems
 - NEMA 250 (National Electrical Manufacturers Association) – Enclosures for Electrical Equipment (1000 Volts Maximum)
 - NFPA 70 – National Electrical Code
 - ISO 1001
 - Occupational Safety & Health Administration (OSHA)

PROTECTION

- Provides overload, surge and undercurrent protection using the latest technology and Guardian Diagnostics to protect system performance and reliability
- Surge protection against load surges as defined in ANSI/IEEE C62.45 category A and B

DIAGNOSTICS, MAINTENANCE AND ACCESSIBILITY

All Prescott 3 sub-assemblies, as well as the battery, are accessible from the front only. The Prescott 3 design will provide maximum reliability and minimum MTTR (mean time to repair). The electronic Prescott 3 control and monitoring assembly is fully microprocessor based. The unit is repairable by replacing standard subassemblies.

- Guardian Diagnostics provides complete self diagnostic capabilities and LED Monitoring
- Microprocessor controlled monitoring system with alarm history logging for diagnostics and maintenance
- Informative, advanced display and alarms allow complete control of the backup environment
- Automatically performs periodic self-tests ensuring a safely lighted environment prior to an emergency
- Single point of testing instead of multiple testing points with battery packs

CABINET

- Modular design enabling flexible installation
- Enclosure: The Prescott 3 is housed in a freestanding enclosure. The mechanical structure of the unit is sufficiently strong and rigid to withstand handling and installation operations without risk. Access to Prescott subassemblies is through the front only. The sheet-metal elements in the structure are protected against corrosion by a suitable treatment, such as zinc electroplating, powder coating, epoxy paint or an equivalent.
- Cable Access: The Prescott allows for side, top and bottom entry cables.
- Ventilation and Heat Rejection: The Prescott designed specifically for forced air cooling. Air inlets are provided in the front, bottom of the Prescott enclosure. Air exhaust is achieved from the top or side portions of the unit.
- Units up to 18kVA are self contained, larger units require an external battery cabinet(s).

INSTALLATION

- Modular design allows easy installation in electrical closet or other convenient locations
- Phone assisted factory start-up standard for all systems
- Extended warranty available
- The Prescott will operate under the following environmental conditions:
 - Temperature:
 - Prescott Module
 - Operating: 0° to 40°C (32°F to 104°F)
 - Non-Operating: -20°C to +60°C (-4°F to 140°F)
 - Batteries: 25°C (77°F)
 - Relative humidity (operating and storage): 5 to 95% non-condensing
 - Barometric Pressure:
 - Up to 1000 meters above sea level
 - Up to 2000 meters with ambient temperature less than 28°C
 - Up to 12,000 meters above sea level non operating
 - Audible Noise: <45 dB measured on Response Curve A
- Site Testing and Start-Up – If selected, the inverter system will be checked, started and tested by a manufacturer's qualified field service engineer either by phone start-up (standard) or by optional onsite start up when performed by a factory technician.

DELIVERY, STORAGE, AND HANDLING

- All products are packaged in a manner to prevent penetration by debris and to allow safe delivery by all modes of ground transportation and air transportation where specified.
- Prior to shipping all products are inspected at the factory for damage.
- Equipment is protected against extreme temperature and humidity and is stored in a conditioned or protected environment.
- Equipment containing batteries will not be stored for a period exceeding three months without powering up the equipment for a period of eight hours to recharge the batteries.

WARRANTY

- One (1) year full warranty on system electronics with phone assisted start-up
- Battery warranty one (1) year with nine (9) years pro-rated, Two (2) year full warranty on system electronics when Onsite Startup is selected.
- Five (5) year power train warranty
- Service contracts available

LINE DIAGRAM

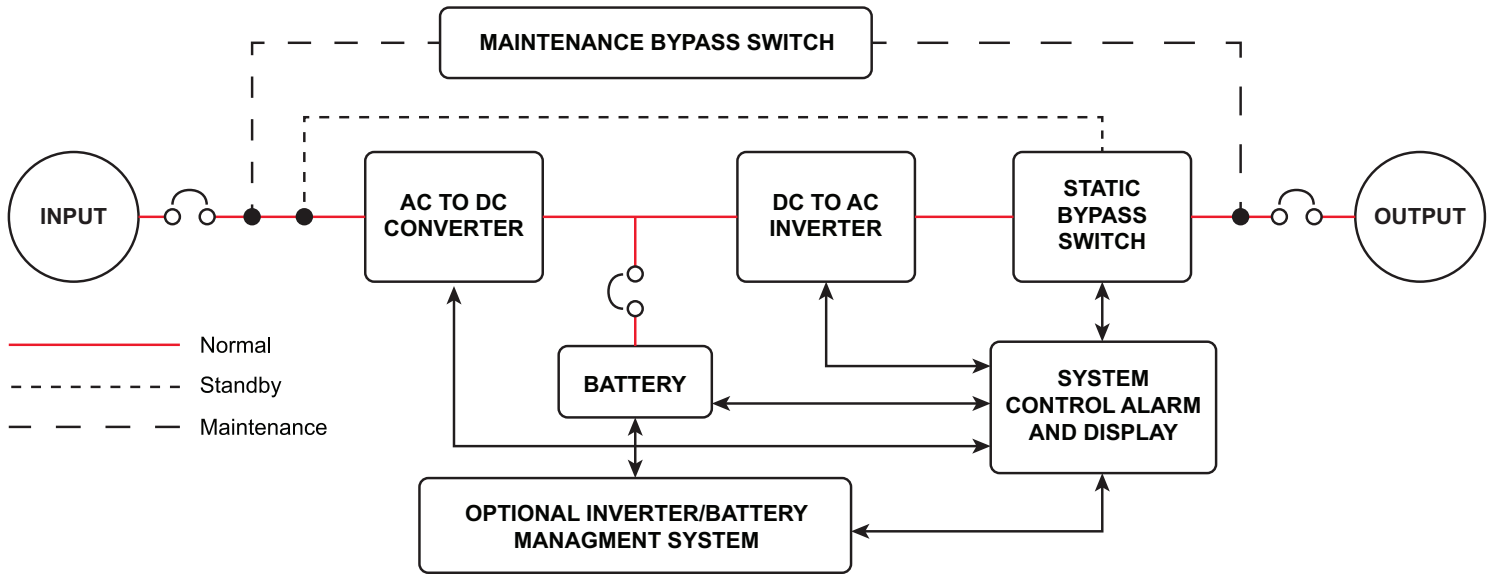

FACTORY INSTALLED ACCESSORY DETAILS

ECM – Environmental Control Module

Used to bypass local switching devices (such as switches, sensors, or relays) during an outage, ensuring emergency circuits remain energized. One ECM is required per switched circuit or device.

NOF – Normally OFF Output Circuit Breaker

Output circuits that remain off during normal operation and activate only when utility power is lost. Ideal for emergency-only loads that should not operate under normal conditions. Allows for direct connection and distribution from the inverter, eliminating the need for separate external panels.

NOH – Normally OFF “Hold ON”

An output breaker that remains OFF during normal operation but includes a programmable “Hold ON” delay to keep the inverter output active for a set time after utility power is restored. This allows for orderly system shutdowns, delayed equipment restarts, and helps prevent inrush current by coordinating with delayed-action systems such as ATS, BAS, or elevator controls.

The delay is user-configurable in 15-second or 15-minute intervals (e.g., 15 sec, 30 sec, 45 sec, 15 min, 30 min, 45 min).

OCB – Output Circuit Breakers

Output breakers that provide circuit-level protection for connected emergency loads. Allows for direct connection and distribution from the inverter, eliminating the need for separate external panels.

EPO – Emergency Power Off

Provides a means to turn off the inverter output during emergencies or maintenance manually. Typically mounted on the outside of the inverter for immediate access.

RP – Remote Indicator Panel

Wall-mounted panel that displays key inverter status indicators such as AC ON, Inverter ON, and Alarm. Enables remote visibility of inverter operation from locations such as control rooms, maintenance areas, or facility management hubs, supporting quick status checks remotely without accessing the unit directly.

SNMP – SNMP Network Interface Card

Provides network-based monitoring and control of the inverter system using the Simple Network Management Protocol (SNMP). The embedded web interface displays real-time system metrics—including voltage, current, power, alarms, and battery status—via a graphical, interactive Java-based webpage. Users can remotely monitor inverter operation, view energy flow animations, and perform key control functions as if operating the front panel locally.

Supports customizable alarm email notifications triggered by specific fault conditions, with up to three severity levels and user-defined recipients. The interface is available in wired (NET232) or wireless (WI232) configurations and is compatible with standard web browsers on LAN-connected devices.

Note: Email functionality requires a non-authenticated SMTP server. Configuration software and installation tools are provided.

FCON – Form C Contacts

Provides isolated, voltage-free relay outputs (dry contacts) for remote signaling of critical inverter status conditions such as System OK, Alarm Active, and On Battery. Designed for seamless integration with Building Automation Systems (BAS), fire alarm panels, and other remote monitoring equipment.

Each contact operates as a Form C relay (single pole, double throw), which provides normally open (NO) and Normally Closed (NC) contact options. Allowing the system to work with different types of monitoring or safety equipment, depending on how signals need to be sent.

SRB – Seismic Rated Brackets

Two floor-mounted L-brackets, 18" (L) × 3" (W), designed to secure the inverter in accordance with seismic installation requirements. Tested to ICC-ES AC156 and certified to meet CBC 2016, IBC, and OSHPD seismic compliance standards. Suitable for Seismic Design Categories A–F. Recommended for installations in seismic zones or facilities with specific compliance mandates.

OST – Onsite Start-Up

A factory-authorized technician performs an on-site visit to activate and bring the inverter system online. This service includes verification of input (feed) power, load connections, battery condition, and overall system functionality. The technician ensures proper configuration and performs operational testing.

Completion of Onsite Start-Up extends the electronics warranty from 1 year to 2 years.

EMB – External Maintenance Bypass Switch

An external switch assembly that allows for maintenance on the UPS without interrupting power to the loads. The make-before-break design connects utility power to the load before disconnecting the inverter, ensuring seamless power transfer. (Not available with integral output circuit breakers.)

EW – Extended Warranty Coverage

Extends the warranty coverage on system electronics for the selected duration, with options available on a per-year basis.

SC – Service Contract

Service Contract for preventive and corrective maintenance over the agreed term.

Additional supporting documents can be found on our [Website](#)

SEISMIC BRACKET DETAILS

Note: Two brackets required per unit.

