

DESCRIPTION

Trace-Lite's LP24 offers incredible performance in an energy-efficient, slim profile package. It is ideal for office spaces, schools, hospitals and any indoor location that requires even illumination and lower maintenance. It is compatible with most standard T-bar grid ceilings, includes 0-10V dimming standard, and can also provide path of egress emergency lighting (LBD).

SPECIFICATIONS

Construction:

- Precision die-formed aluminum housing
- Recessed design fits most standard T-bar grid ceilings
- White polyester powder coat finish
- Diffused lens
- Suitable for Damp Locations

Optics/ LEDs:

- L70 at 81,000hrs (36W)
- L70 at 63,000hrs (68W)

Electrical:

- High-performance isolated driver features overvoltage, overcurrent and short-circuit (with auto-recovery) protection. Class A sound rating, 0-10V dimming included standard (10% - 100%)
- 120-277VAC, 50/60Hz
- >0.9 power factor
- Total harmonic distortion: <20%

Testing & Compliance:

- ETL Listed for Damp Locations and insulated ceilings (IC Rated)
- cULus Listed for Damp Locations and insulated ceilings (IC Rated)
- DesignLights Consortium® (DLC) Qualified
- LP24-36 is DLC PREMIUM Qualified
- Operating Temperatures:
(36W) -25°C to 50°C (-13°F to 122°F)
(68W) -25°C to 45°C (-13°F to 113°F)

Installation:

- Unit simply lifts through grid ceiling and rests on T-bars
- Easy installation in new construction or retrofit
- Standard mounting includes recessed mounting in grid ceilings
- Earthquake clips included

Accessories:

- Optional surface mounting kit is available (LP24-SMK)
- Optional flange mounting kit for recessed drywall applications (LP24-FMK)
- Field-installable battery packs available for emergency egress lighting (LBD)

Warranty:

- Five Year Warranty (Terms and Conditions Apply)

Model: _____ Date: _____
Accessories: _____
Job Name: _____ Type: _____

Available While Supplies Last



Specs at a Glance					
Wattage (W)	36	68			
CCT (K)	4000	3000	3500	4000	5000
Lumens (lm)	4589	6567	6645	6645	7325
Efficacy (LPW)	126	97	98	98	108
CRI	>80				
Input Voltage	120-277VAC, 50/60Hz				
Warranty	5 Years				
Ambient Temp	-25°C to 50°C (-13°F to 122°F)		-25°C to 45°C (-13°F to 113°F)		
Certifications	cULus Listed, DLC Premium		ETL Listed, DLC		
	IC Rated, Suitable for Damp Locations				
Weight	13.6 lbs	15.5 lbs			

Ordering Information (Example: LP24-36-3K)

Series	Fixture Watts	Color Temperature (CCT)	Options (Factory Installed)
LP24 ¹ = 2' x 4' Ultra-thin LED Panel	36 ² = 36 Watts	3K ⁴ - 3000 Kelvin	MC6 ⁵ = 6' Line Cord (Metal Corrugated Sleeving)
	68 ³ = 68 Watts	35K ⁴ - 3500 Kelvin	
Notes		4K - 4000 Kelvin	Accessories⁸ (Field Installed)
¹ Sold two (2) units per pack		5K ⁴ - 5000 Kelvin	LBD-5-NC-CW-C ^{6,7} = 5 Watt Battery Pack for Emergency Egress
² L70 @ 81,000hrs, UL listed product, DLC Premium Qualified			LBD-7-NC-CW-C ^{6,7} = 7 Watt Battery Pack for Emergency Egress
³ L70 @ 56,000hrs, ETL listed product, DLC Qualified			LBD-10-NC-CW-C ^{6,7} = 10 Watt Battery Pack for Emergency Egress
⁴ 3000K, 3500K and 5000K Not available on 36W units			LBD-13-NC-CW-C ^{6,7} = 13 Watt Battery Pack for Emergency Egress
⁵ Option not currently UL Listed			LBD-17-NC-CW-C ^{6,7} = 17 Watt Battery Pack for Emergency Egress
⁶ See back page for battery pack lumen output			LP-EMBKT = LBD Mounting Bracket
⁷ Not compatible with LP24-SMK			LP24-FMK = Flange Mount Kit
⁸ Order as separate line item			LP24-SMK = Surface Mount Kit

Dimensions

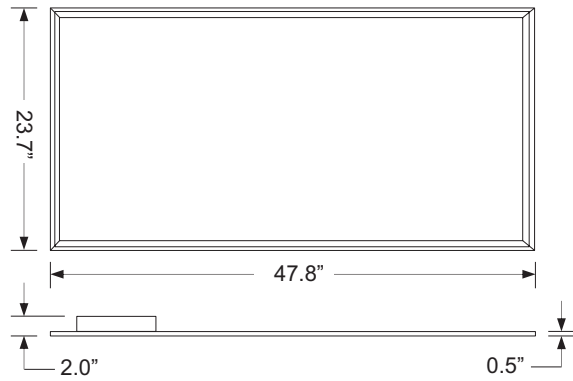

Fixture Watts	Weight
36 = 36 Watts	13.6 lbs
68 = 68 Watts	15.5 lbs

Sample Photometry

LP24-68-3K

IES: TYPE II Very Short

MOUNTING HEIGHT: 10'

TILT: ZERO

HORIZONTAL SPACING CRITERIA: 1.20

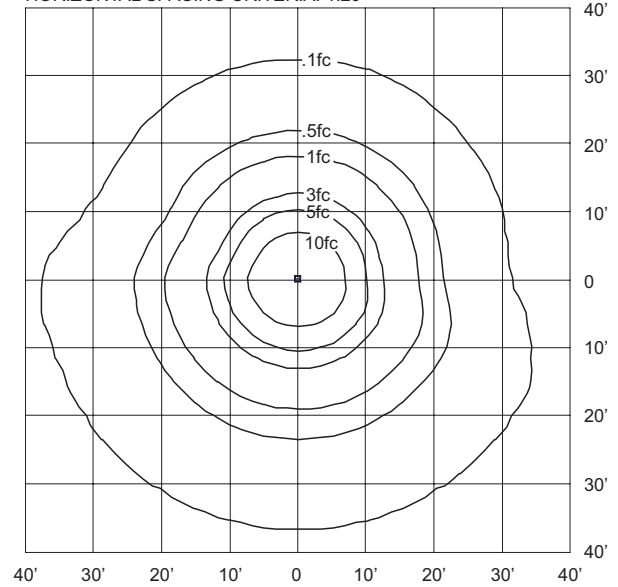

Surface Mount Kit

Optional surface mounting kit (LP24-SMK) allows for installation on plaster or other hard ceilings.

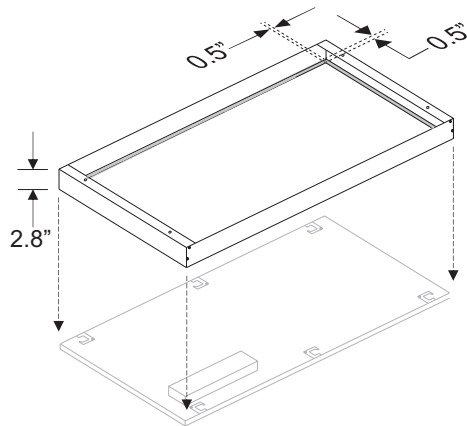

Flange Mount Kit

Optional flange kit (LP24-FMK) mounts above the drywall ceiling and allows the panel to be mounted flush to the ceiling.

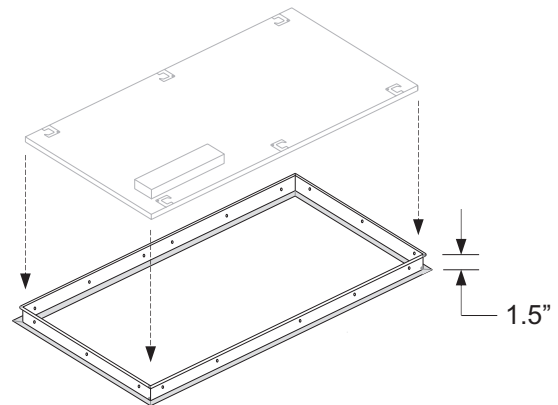

Lumen Output Summary for LBD Battery Pack Accessories

LP Panel Battery Packs:			LBD-5-NC-CW-C	LBD-7-NC-CW-C	LBD-10-NC-CW-C	LBD-13-NC-CW-C	LBD-17-NC-CW-C
Model	Lumens	Wattage	Battery Back Up Lumens				
LP24-36-4K	4589	36	510	795	1091	1397	1815
LP24-68-3K	6567	68	386	603	827	1058	1375
LP24-68-35K	6645	68	391	610	836	1071	1392
LP24-68-4K	6645	68	391	610	836	1071	1392
LP24-68-5K	7325	68	431	672	922	1181	1534

Specifications are subject to change without notice. Installation must be performed in accordance with Barron Lighting Group installation instructions.