

SCL Series

Specification Grade Compact LED Emergency Lighting Unit with Tool-less Battery Access



Long Life LED
Up to 60ft Spacing
Tool-less Battery Access
Numeric Fault Indicator



ASSEMBLED IN
USA
WITH GLOBAL COMPONENTS

5/5
WARRANTY

BARRON EXITRONIX
emergency lighting

SCL Series

Compact Steel LED Emergency Lighting Unit with Tool-less Battery Access

The SCL Series combines maintenance innovations with performance and dependability in a compact specification grade steel enclosure.

Standard Features

- Tool-less front battery accessibility for ease of maintenance
 - Isolated battery compartment for safe installation and maintenance
 - Hinged door helps prevent loss or misplacement during installation and maintenance
- Patent pending Numeric Indicator option for error-proof visual display of fault detection/status (G2-NI)
- Fully adjustable PAR16 style (REN3M) 3.6W or (REN3) 2.9W LED lamps deliver industry-leading spacing up to 60'
- Compact enclosure constructed of rugged 20 gauge steel, White finish
- Maintenance-free 6V NiMH battery
- Brownout, low voltage, overload and short circuit protection standard
- 90 minute emergency run time, 24 hour recharge time
- 120/277VAC dual primary, 50/60Hz input
- Assembled in the USA with global components
- 5 year fixture/ 5 year pro-rated battery warranty



Numeric Indicator (G2-NI) for dependable visual status and fault detection.



Tool-less hinged door for easy and safe access to isolated low voltage battery compartment.

Dimensions

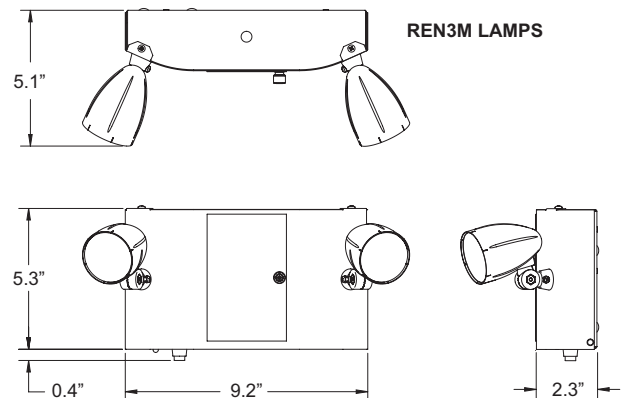

Ordering Information

Model	Description	Accessories ¹ (Field Installed)
SCL-8-REN3-2-W-G2	8W, 2 Renegade 2.9W LED Lamps, Self-Test/Self-Diagnostics, White	ER1-KIT-WH = 1' Pendant Kit, White
SCL-8-REN3M-2-W-G2-NI	8W, 2 Renegade Max 3.6W LED Lamps, Self-test/Self-diagnostics with Numeric Indicator, White	ER2-KIT-WH = 2' Pendant Kit, White
		WG-S = Wire Guard (Back Mount)

Notes

¹ Order as separate line item

Please visit our website for the latest information.

10840163 Rev 4

