

IMPORTANT SAFEGUARDS READ AND FOLLOW ALL SAFETY INSTRUCTIONS.

When using electrical equipment, basic safety precautions should always be followed including the following:

- **CAUTION: Do not join converter connector until installation is complete and AC Power is supplied to the emergency driver,**
- This product is for use with an emergency LED lighting load and supplies a maximum of 7W, 10W or 21W of power and a maximum voltage of 48VDC in emergency mode for a minimum of 90 minutes.
- To reduce the risk of electric shock, disconnect both normal and emergency power supplies and converter connector of the emergency driver before servicing.
- This emergency driver is suitable for both factory and field installation.
- This product is suitable for use in dry and damp locations.
- The ambient temperature for use is 0°C to 50°C (32°F to 122°F).
- Do not install outdoors.
- An unswitched AC power source of 120/277VAC, 60Hz is required.
- Do not install near gas or electric heaters.
- The use of accessory equipment not recommended by the manufacturer may cause an unsafe condition.
- Install in accordance with the National Electrical Code or Canadian Electrical Code and any local regulations.
- Do not use this product for other than intended use.
- Servicing should be performed by qualified service personnel.
- Equipment should be mounted in locations and at heights where it will not be subjected to tampering by unauthorized personnel.
- For use with a metal grounded enclosed wiring system or equivalent.

SAVE THESE INSTRUCTIONS!

Technical Support ■ (623) 580-8943 ■ technicalsupport@barronltg.com

Checklist Before Installation

This product is suitable for field installation with suitable LED loads including LED luminaires, DC voltage driven LED replacements for fluorescent lamps and others. To determine if your luminaire is eligible for field installation, please check the 4 items in the following checklist.

1. Verify the LED load's rated power is greater than or equal to the power output of this emergency LED driver. This is to ensure that this emergency product will not produce more power than the LED load can handle, thus ensuring that the LED load will not be damaged when the system is in the emergency mode.
2. Ensure that the forward voltage of the luminaire's LED array is within the limits of this emergency LED driver. The forward voltage of the LED array is commonly designated as Vf and should be found on the luminaire markings, in the luminaire specifications, or imprinted directly on the LED arrays. If multiple LED arrays are to be driven, verify that the total forward voltage is within the limits of this product. Using a voltage meter, it may be possible to directly measure the voltage across the LED arrays when operating from the AC driver.
3. Ensure the output current of the LED driver does not exceed 5.0 Amps. This is the current into the red wire.
4. Calculate the end use application's emergency illumination levels. You can estimate the egress lighting illumination by doing the following:
 - A. Find the efficacy of the LED load, which will be found in the Design Lights Consortium database. This number will be given in lumens per watt (lm/w). It is the installer's responsibility to validate the luminaire manufacturer's efficacy data. This can be accomplished by direct measurement, by review of independent 3rd party test data (UL, ETL, etc.), accessing a public database of 3rd party data (such as Design Lights Consortium, www.designlights.org), or other comparable means.
 - B. Lumens can be calculated by multiplying the output power of the emergency LED driver by the efficacy of the LED load. In many cases the actual lumen output in emergency mode will be greater than this calculation gives, however it will provide a good estimate for beginning the lighting design of the system. (Fig. 1)

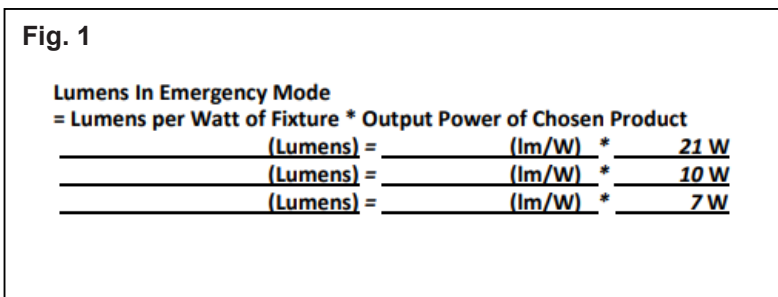

- C. Using the results of this calculation and industry standard lighting design tools, calculate the anticipated illumination levels in the path of egress.

NOTE:

This product has been designed to reliably interface with a wide selection of LED loads and is electrically compatible with every simple LED array that meets criteria 1 and 2 above. However, compatibility cannot be guaranteed with all current and future LED systems. Compatibility testing of the end-use system is suggested. Please contact the factory with any questions.

After installation, it is necessary to measure the egress lighting illumination levels to ensure it complies with national, state, and local code requirements. Typically 1 fc on the ground along the full means of egress.

Installation

CAUTION: The LEMDC with the polycarbonate case must be installed inside of a luminaire or similar housing which meets the UL requirements for enclosures. The polycarbonate case nor external battery (where applicable) is not suitable for installation outside of the luminaire's protective enclosure

NOTE: Make sure the necessary branch circuit wiring is available. An unswitched source of power is required. The emergency driver must be fed from the same branch circuit as the AC driver.

Installation of this emergency LED driver will vary based on the luminaire type, however, generally follow these steps.

1. Installing the emergency driver:

- Disconnect AC power from the LED luminaire.
- Mount the emergency LED driver by the mounting tabs.
- Mount the battery in the same enclosure with the driver using supplied mount bracket.
- For emergency backup driver supplied with conduit, connect the wires in the junction box.
- Mounting Height: This product meets or exceeds the NFPA minimum light requirements with all loads, down to the smallest rated lamp load, at heights up to 7.17ft (2.2m). For field installations, when the attached luminaire is mounted at heights greater than 7.17ft (2.2m), the level of illumination must be measured in the end application to ensure the requirements of NFPA 101 and local codes are satisfied.

2. Installing the multi-function testing switch (MFTS) on fixture surface:

- Mount the supplied MFTS in a location that is visible and accessible by maintenance personnel. The MFTS mounts through a ½" hole which may need to be made in the luminaire or could come pre-punched by the luminaire supplier.
- Wire the test switch per wiring diagrams provided on these instructions. (Fig. 2)
- If wired correctly, the MFTS indicator light should be ON when AC power is supplied to the fixture, and the converter connector is closed indicating that the emergency inverter battery is charging. After installing, mark with the "PUSH TO TEST" and "CHARGING INDICATOR LIGHT" labels.

3. Wiring the emergency driver:

- Select the appropriate wiring diagram to connect the emergency driver to the AC driver and LED load. Make sure all connections are in accordance with the National Electrical Code and any local regulations. (Fig. 2)
- After installation is complete, supply AC power to the emergency driver and join the converter connector.
- At this point, power should be connected to both the AC driver and the emergency driver, and the Charging Indicator Light should illuminate indicating the battery is charging.
- A short-term discharge test may be conducted after the emergency driver has been charged for one hour. Charge for 24 hours before conducting a long-term discharge test. Refer to OPERATION.
- In a readily visible location, attach the label "CAUTION - This Unit Has More Than One Power Connection Point. To Reduce The Risk Of Electric Shock, Disconnect Both The Branch Circuit-Breakers Or Fuses And Emergency Power Supplies Before Servicing."

Wiring Diagram

CAUTION: Typical schematics only. Consult the factory for other wiring diagrams. Emergency driver and AC driver must be fed from the same branch circuit.

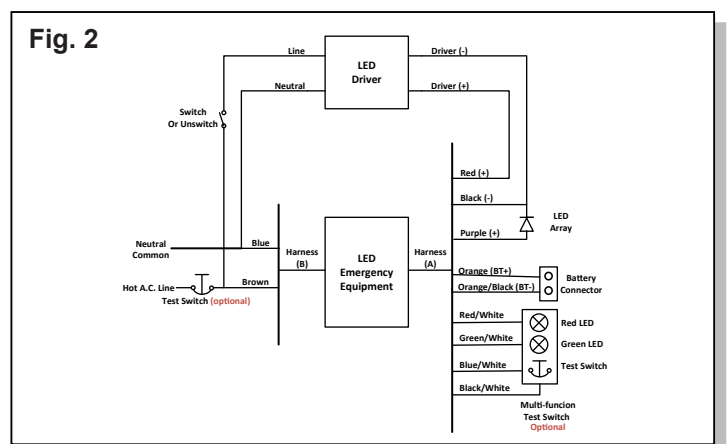

Output Current Setting

Model: LEMDC-7-LP-CC						
Current	Volts	Pwr	Micro-Switch			
A	Vdc	W	SW1	SW2	SW3	SW4
440	16	7	on	---	---	---
290	24	7	---	on	---	---
195	36	7	---	---	on	---
145	48	7	---	---	---	on

Model: LEMDC-10-LP-CC						
Current	Volts	Pwr	Micro-Switch			
A	Vdc	W	SW1	SW2	SW3	SW4
625	16	10	on	---	---	---
425	24	10	---	on	---	---
280	36	10	---	---	on	---
210	48	10	---	---	---	on

Model: LEMDC-21-LP-CC						
Current	Volts	Pwr	Micro-Switch			
A	Vdc	W	SW1	SW2	SW3	SW4
875	24	21	on	---	---	---
580	36	21	---	on	---	---
500	42	21	---	---	on	---
435	48	21	---	---	---	on

SW5: ON, SW6: ON

Operation

The battery in this unit may not be fully charged. After electricity is connected to the unit for at least 24 hours, then normal operation of this unit should take effect. During normal operation AC power is applied, the charging indicator light is illuminated, indicating that the battery is being charged. When power fails, the emergency LED driver automatically switches to emergency power (internal battery), operating the LED load for a minimum of 90 minutes. When AC power is restored, the emergency driver returns to the charging mode.

In accordance with NFPA 101, your emergency lighting system must be tested monthly for a minimum of 30 seconds and annually for 90 minutes. Refer to your local codes for any additional requirements that may apply.

Self-Testing Operation (-G3/G3PRO models)

This unit automatically performs a 30-second discharge test every month, and a full 90-minute discharge test once a year. During routine testing, the self-testing emergency driver simulates an AC power failure causing the unit to automatically switch to emergency mode. The unit will monitor the operation of the lighting fixture, internal battery voltage, discharging current, and emergency duration. If the emergency system functions properly, then the unit will return to normal mode. Should the unit detect any problems, the indicator light will flash continually until the condition has been corrected and the unit passes the next test. Please refer to **Troubleshooting Guide**.

- If the unit pass the self-diagnostic test successfully, the message will be cleared automatically after 24hrs. If the unit fails during the test, the indicator light continues flashing until the condition has been corrected or cleared manually.
- If the condition has not been corrected by the next scheduled test, the unit will once again detect the failure and signal the failure indicator.
- To cancel a test, press and hold the Multifunction Button ONCE for less than 1 seconds.
- To perform manual self-test push and hold Multifunction button for a minimum of 3 second. Once button is released, emergency driver will perform the 90 second diagnostic test. After Self-testing is completed, the indicator light will flash per testing results. Please refer to **Troubleshooting Guide**.

Maintenance

This self-testing emergency driver automatically performs required routine testing. Results are reported to maintenance personnel via the indicator lights. Although no routine maintenance is required to keep the emergency driver functional, the indicator lights should be checked periodically. If the indicator lights are flashing, go through all steps of **Troubleshooting Guide**.

Troubleshooting Guide

STATUS INDICATORS		PROBLEM	CORRECTIVE ACTION
Green Light	Red Light		
ON steady	OFF	NONE	None, Unit is fully charged and working correctly.
Flashing Slow (2s interval)	OFF	NONE	None, Unit is in Charging mode.
OFF	ON Steady	NONE	None, AC is lost and Unit is in Emergency Discharging mode.
OFF	Flashing Slow (2s interval)	NONE	None, Unit is in Self-testing mode.
Flashing (0.5s ON-OFF)	Flashing (0.5s OFF-ON)	NONE*	None, Unit is NOT in any network. Join if needed.
Flashing Fast (0.5s interval)	OFF	NONE	Press test button to clear message. Unit has passed Self-testing.
OFF	Flashing Fast (0.5s interval)	Self-testing Fail	1. Check the wiring. 2. Allow unit to charge for 24 hours. Perform manual test. If failure mode continues, emergency driver should be replaced.
Flashing 0.5s ON-OFF	Flashing 0.5s-0.5s	Self-testing Interrupted	
OFF	Flashing (0.5s-0.5s-2s)	LOAD FAIL	Check the load wiring or functionality.
OFF	OFF	Battery Failure	1. Check the battery Connector. 2. If battery connection is good, the battery or emergency driver should be replaced.

*For "-G3/-G3PRO" models only

Networking Operations for "-G3/G3PRO" Models

NOTE: Wireless operation provides an optional monitoring and remote testing function. The unit will still be functional without wireless network connected.

By using the Guardian G3 monitoring software with the wireless controller, the battery information and EM driver status can be monitored remotely. The software will monitor the operation of the lighting fixture (ON or OFF), battery voltage and battery remaining capacity. In addition, you can monitor the following via the above software and wireless controller:

- Charging Mode = When the battery is getting charged.
- Idle Mode = when the battery is fully charged.
- Testing Mode = When the user wants to run the unit on battery mode for a certain period of time in minutes.
- Working Mode = Running the unit in emergency mode.

Model with "-G3/G3PRO" suffix is our world winning design equipped with "wireless testing and reporting" features. Unit that has "-G3/G3PRO" suffix in its model number is capable of joining Guardian G3 emergency lighting management system. It will be part of a large testing system to be tested and report result wirelessly.

Once powered up and commissioning allowed, unit will automatically join Guardian G3 network and get provisioned. Upon the completion of the commissioning, unit will perform testing and report based on set schedules.

For more information about commissioning, configurations and testing, please visit website, <https://barrontlg.com/guardian-g3-products.php> for details.

LEMDC Series

Installation Instructions

Dimensions

LEMDC-7-LP-CC & LEMDC-10-LP-CC & LEMDC-21-LP-CC

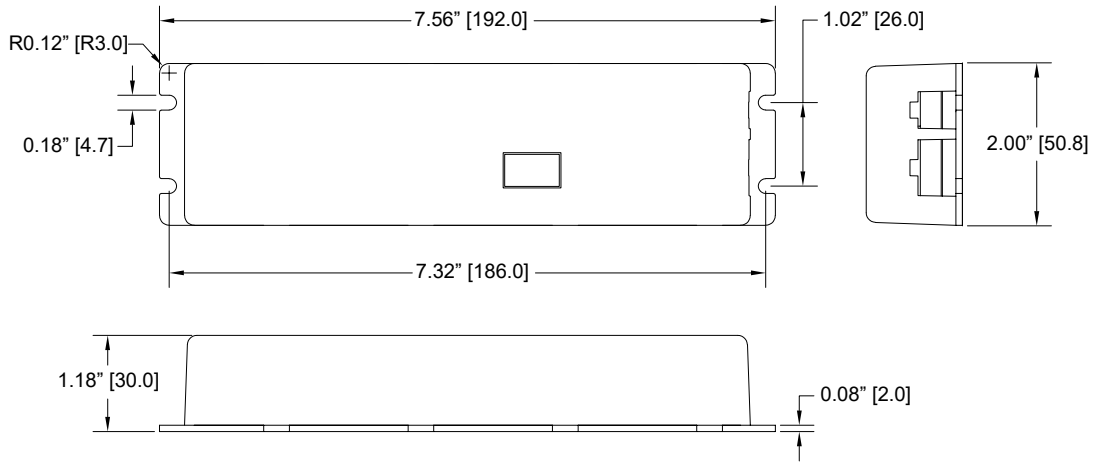

Battery Pack Dimensions - 7/10W

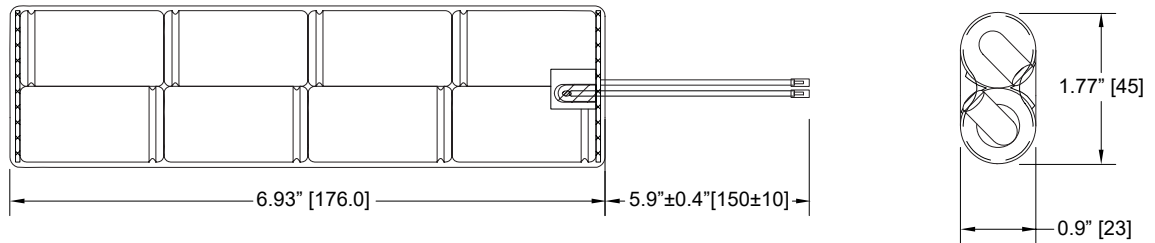

Battery Pack Dimensions - 21W

