

The LEM54-N4 thermoplastic emergency lighting unit combines a low-profile, contemporary appearance with economy and dependability. Constructed of an injection-molded, V-0 flame rated, high-impact, UV-stabilized thermoplastic housing, it is ideal for high vandalism, wet locations and is resistant to corrosive atmospheres and non-hazardous dust environments. It's compact, streamlined design features fully adjustable LED heads to complement any environment and will provide years of reliable service.

### FEATURES & BENEFITS

- Fully adjustable, high-intensity LED heads, up to 18' on-center spacing
- UL 94 V-0 flame-retardant thermoplastic components
- Optional I-beam and pole mounting bracket available (IHB)
- UL Listed 90 minute emergency run time, 24 hour recharge time
- Waterproof shield makes the unit suitable for Wet Locations

### SPECIFICATIONS

illumination:	Fully adjustable, high-intensity LED lamps
Housing:	UL 94 V-0 flame-retardant polycarbonate
Input:	120/277VAC Dual primary, 60Hz
Battery:	Maintenance-free NiCad battery
Operating Temp:	-20°C to 50°C (-4°F to 122°F)
Run Time:	UL Listed 90 minute emergency run time, 24 hour recharge time
Mounting:	Ceiling or wall mount, optional I-beam and pole mounting bracket available
Finishes:	Black or white
Certifications:	UL 924 Listed, meets or exceeds NEC requirements and NFPA 101
Warranty:	Any component that fails due to a manufacturing defect is guaranteed for five years with a separate five year prorated warranty on the battery. The warranty does not cover physical damage, abuse or instances of uncontrollable natural forces. See the full Exitronix warranty document for detailed information. (Terms and Conditions apply)

Model: \_\_\_\_\_ Date: \_\_\_\_\_  
 Accessories: \_\_\_\_\_  
 Job Name: \_\_\_\_\_ Type: \_\_\_\_\_

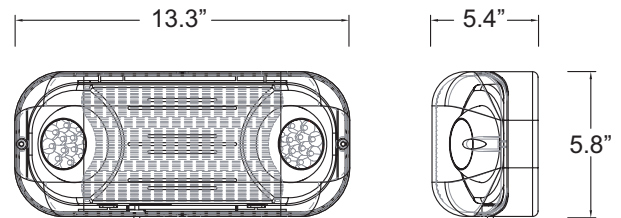

### ORDERING INFORMATION Example: LEM54-N4-BL

Model	Description
LEM54-N4-BL	Thermoplastic High Impact Emergency Light, (2) LED Lamps, 3.6V NiCad Battery, Black Finish, Wet Location Rated
LEM54-N4-WH	Thermoplastic High Impact Emergency Light, (2) LED Lamps, 3.6V NiCad Battery, White Finish, Wet Location Rated

Accessories <sup>1</sup> (Field Installed)	
<b>Notes:</b>	IHB = I-Beam and Pole Mounting Bracket
<sup>1</sup> Order as separate line item	WG-S = Wire Guard (Back Mount)

### CONSTRUCTION

Precision molded unit and lamp housings constructed of UV stable UL 94 V-0 flame-retardant, corrosion-proof thermoplastic. Units resist denting, peeling, scratching and are vandal resistant.

### ILLUMINATION

The emergency unit consists of two fully adjustable LED lamps with a beam angle of 36° that allows for maximum light to be delivered to the path of egress.

### ELECTRICAL

#### Input

Dual-voltage input 120 or 277VAC @ 60Hz.

#### NiCad Battery

Extronix NiCad batteries are maintenance-free with a life expectancy of 15 years. NiCad batteries perform optimally in temperatures ranging from 32°F to 104°F (0°C to 40°C).

#### Emergency

The LEM54-N4 will operate for a minimum of 90 minutes during a loss of power with a 24 hour maximum recharge time for the battery.

### Solid-State Transfer

The switching circuit is designed to detect a loss of AC power and automatically energizes the lamps. Upon restoration of the AC voltage, the emergency lamps will switch off and the charger will automatically recharge the battery.

### Test Button

Our easily located test button allows for manual verification of proper operation of the transfer circuit and emergency lamps.

### INSTALLATION

A universal mounting pattern for 3" and 4" J-box and rear keyhole slots are provided for wall mounting. Optional I-beam mounting bracket is available for mounting to poles, I-beams or strut metal framing.

### Wet Location Rated

Wet Location rating ensures the fixture is designed to operate safely in indoor and outdoor locations that are subjected to elements such as damp, dust, wet and hose down areas.

### CONFORMANCE TO CODES & STANDARDS

The LEM54-N4 Series is UL Listed and meets or exceeds the following: UL 924, NEC requirements, NFPA 70 and NFPA 101.

### SAMPLE PHOTOMETRICS

Using multiple LEM54-N4 units mounted at a typical 7.5' height delivers 18' on center spacing with a 3' wide path of egress.

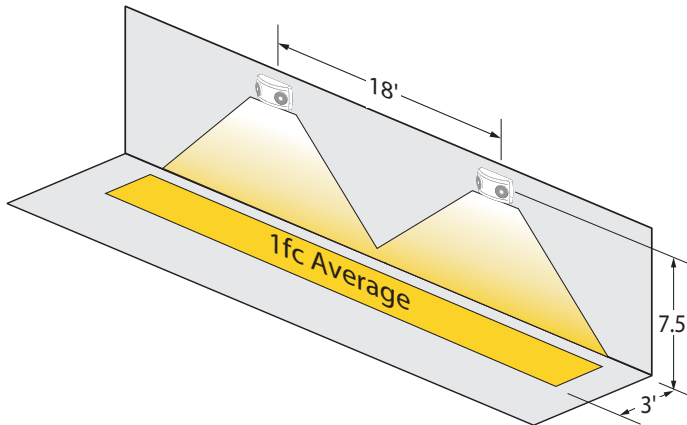

Using multiple LEM54-N4 units mounted at a typical 7.5' height delivers 12' on center spacing with a 6' wide path of egress.

