



IMPORTANT SAFEGUARDS READ AND FOLLOW ALL SAFETY INSTRUCTIONS.

When using electrical equipment, basic safety precautions should always be followed including the following:

- **DISCONNECT AC POWER SUPPLY BEFORE SERVICING.**
- Installation and servicing of this equipment should be performed by qualified service personnel only.
- Ensure that the electrical wiring conforms to the National Electrical Code NEC® and local regulations if applicable.
- Do not mount near gas or electrical heaters.
- Do not use outdoors.
- Equipment should be mounted in locations and at heights where it will not be readily subjected to tampering by unauthorized personnel.
- The use of accessory equipment not recommended by the manufacturer may cause an unsafe condition.
- Any modification or use of non-original components will void the warranty and product liability.
- Do not use this equipment for other than intended use.
- Allow battery to charge for 24 hours before first use.

SAVE THESE INSTRUCTIONS!

Technical Support ■ (623) 580-8943 ■ technicalsupport@barronltg.com

HAE Series

Installation Instructions

Top Mount/Side Mount Installation

1. Position the fixture housing against the ceiling surface, ensuring it is level. The housing includes four 5/16" knockouts for fasteners and a 7/8" knockout for wiring. Mark and drill holes for the appropriate mounting hardware (Refer to **Additional Mounting Hardware Instructions** section). (Fig. 1)
2. Route AC supply leads make the proper wire connections. Connect the white wire to neutral. If using 120VAC, connect the black wire to the hot lead. If using 277VAC, connect the red wire to the hot lead. Cap the unused lead. Refer to the **Wiring Diagram** section. (Fig. 5 on pg 4)
3. Feed excess wire back into junction box and secure the fixture housing against the ceiling/wall tightly.
4. Remove fasteners from the fixture door. Lift the door out of the fixture and set aside. Remove the EXIT frame by unscrewing the bracket fasteners and removing both EXIT frame brackets along with the EXIT frame. (Fig. 3)
5. Snap chevrons out of the EXIT front cover as needed and re-secure the door to the housing using the appropriate fasteners removed earlier. (Do not torque door fasteners to more than 28lb of torque.)

IMPORTANT: For wet location option, to ensure a moisture-proof seal, avoid damaging the gasket during installation. Door frame fasteners must have washers to ensure a proper seal.

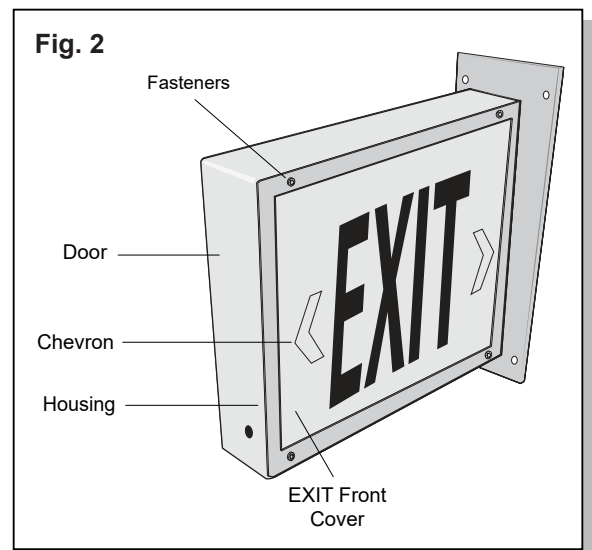
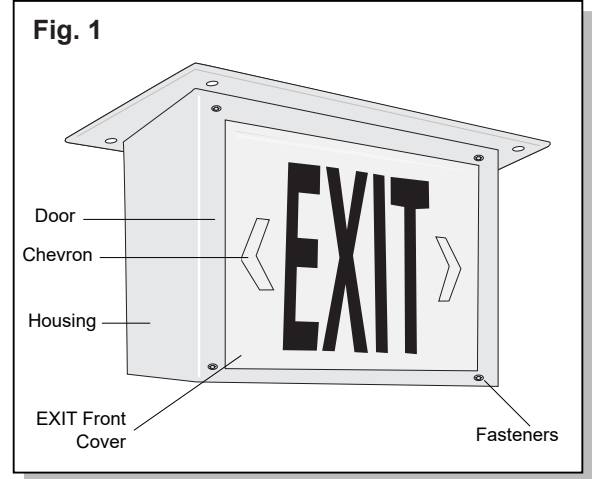

HAE Series

Installation Instructions

Wall Mount Installation

1. Remove fasteners from the fixture door. Lift the door out of the fixture and set aside. Remove the EXIT frame by unscrewing the bracket fasteners and removing both EXIT frame brackets along with the EXIT frame. (Fig. 3)
2. Position the fixture housing against the wall surface, ensuring it is level. The housing includes four 5/16" knockouts for fasteners and a 7/8" knockout for wiring. Mark and drill holes for the appropriate mounting hardware (Refer to **Additional Mounting Hardware Instructions** section). (Fig. 4)
3. Route AC supply leads through the center hole on the housing. Place fixture housing against the wall surface and secure tightly.
4. Make the proper wire connections. Connect the white wire to neutral. If using 120VAC, connect the black wire to the hot lead. If using 277VAC, connect the orange wire to the hot lead. Cap the unused lead. Refer to the **Wiring Diagram** section. (Fig. 5 on pg 4)
5. Feed excess wire into the housing and re-secure the EXIT frame to the housing by using the EXIT frame bracket fasteners.
6. Snap chevrons out of the EXIT front cover as needed and re-secure the door to the housing using the appropriate fasteners removed earlier. (Do not torque door fasteners to more than 28lb of torque.)

IMPORTANT: For wet location option, to ensure a moisture-proof seal, avoid damaging the gasket during installation. Door frame fasteners must have washers to ensure a proper seal.

Additional Mounting Hardware Instructions

GYPSUM OR TILE SURFACES: Since mounting surfaces vary, four (4) fasteners (provided by others) must be provided for the mounting plate. A sturdy brace that matches the hole pattern is also recommended.

WOOD BRACE: Lag bolts are recommended for wood braces.

METAL BRACE: Self-tapping screws are recommended for metal braces.

CONCRETE/CINDER BLOCK: When installing the fixture on a concrete ceiling, an appropriate anchor set is recommended that requires bracing.

NON-ABUSIVE ENVIRONMENT: Toggle bolts may be used without bracing.

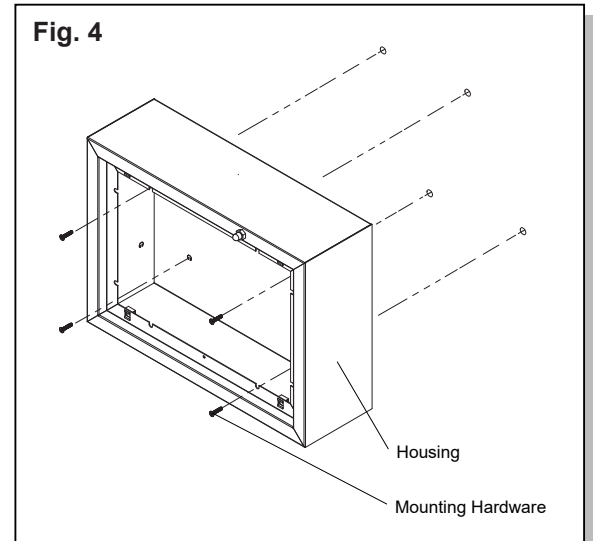
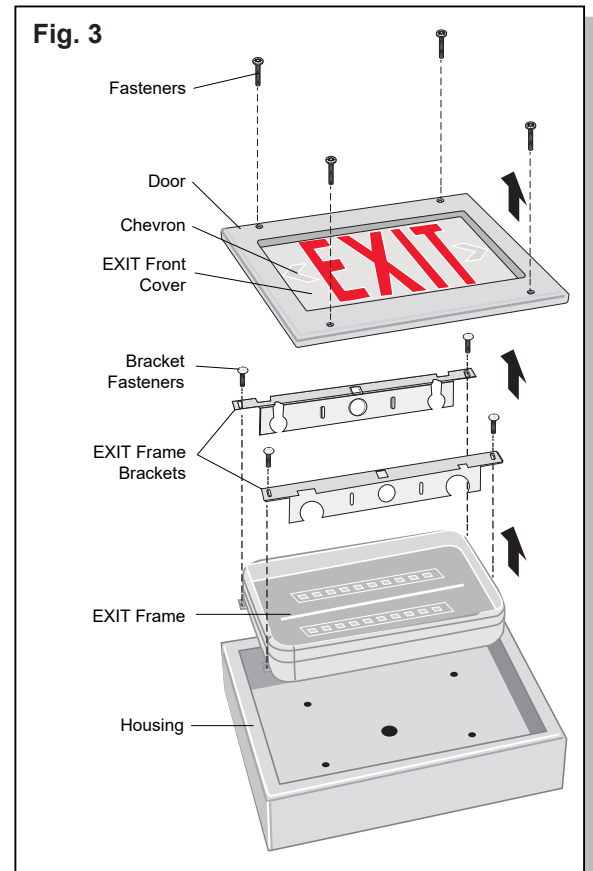

HAE Series

Installation Instructions

Wiring Diagram (Fig. 5)

Note: The fixture cover is designed to conceal a typical junction box. A 7/8" knock-out is provided to feed power to the fixture. Cap off the UNUSED input lead. Failure to do so can cause an unsafe operating condition.

- If using 120VAC, connect the black and white wires to the building utility.
- If using 277VAC, connect the red and white wires to the building utility.

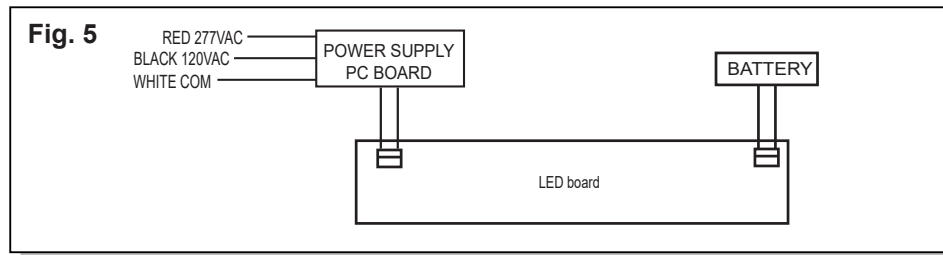

Operation (Battery Backup)

The battery in this unit may not be fully charged. After electricity is connected to the unit for at least 24 hours, then normal operation of this unit should take effect. To check, press the "TEST" button. The EXIT sign should stay illuminated by battery backup and the LED indicator will be turned off. Release the "TEST" button, LED indicator will be turned on. To locate the test button, refer to Fig. 6 for the top mount and Fig. 7 for the side mount.

Top Mount

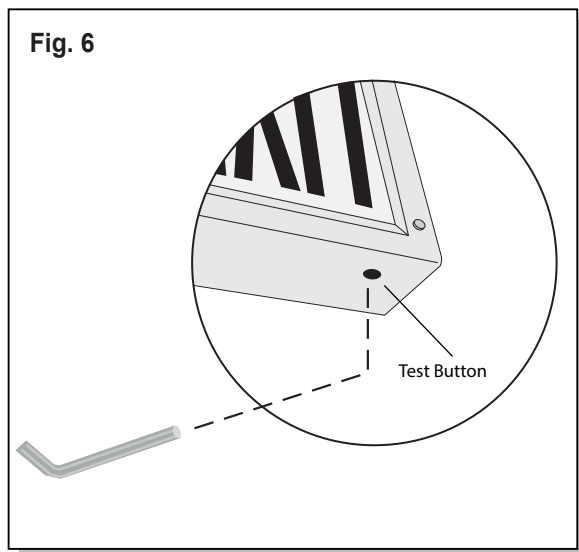



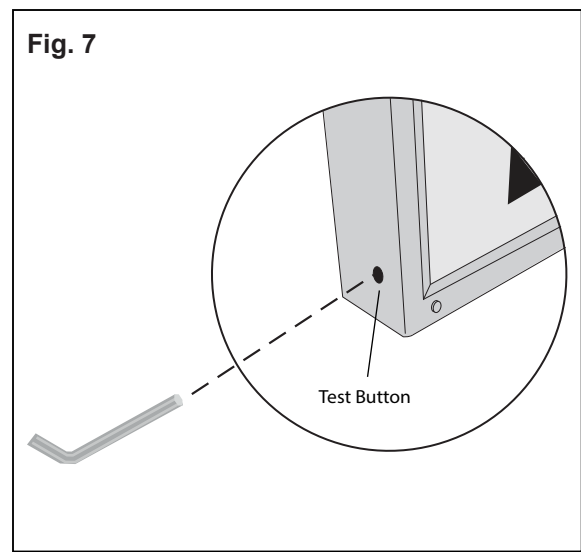

Side Mount



In accordance with NFPA 101, your emergency lighting system must be tested monthly for a minimum of 30 seconds and annually for 90 minutes. Refer to your local codes for any additional requirements that may apply.

Testing and Reporting Instructions (-G2 models)

- When AC power is supplied to fixture, the unity will automatically initiate a self-test and self-diagnostic test as follows:
 - Verifies battery disconnection, charger board failure at every 5 seconds.
 - 1 minute self-testing every month.
 - 30 minutes self-testing on every 6 months after installation.
 - 90 minutes self-testing on every 12 months after installation.
- Dual color LED lamp indicator shows the following status:
 - Green color: On / Ready
Blinking: Testing
 - Red color: (Service Alert)
 - Service Alert LED Code (Red color LED lamp indicator)

| | | |
|---|-----------------------------------|--------------------------|
|  | Steady ON | Battery Disconnected |
|  | One blinks ON/pause (4 seconds) | Battery Recharge Failure |
|  | Two blinks ON/pause (4 seconds) | Battery Failure |
|  | Three blinks ON/pause (4 seconds) | LED Failure |

Note: After solving the fault of emergency equipment, please press test button for 2 seconds then release to reset. LED indicator will show green.

- “-G2” models also have a manual test function, press test button as follows:

| | | |
|-------------------------------|--------------------|---------------------------|
| Press Test Button Once | (within 2 seconds) | 30 Seconds Discharge Test |
| Press Test Button Twice | (within 2 seconds) | 30 Minutes Discharge Test |
| Press Test Button Three Times | (within 2 seconds) | 90 Minutes Discharge Test |