

DESCRIPTION

The Exitronix EMD Series LED Backup Driver is specifically designed to provide emergency lighting of LED fixtures with the loss of power. The unit is suitable for most pre-installation and on-site applications requiring emergency illumination.

SPECIFICATIONS

Construction

- Unit provided with 12" conduit on one end
- Remote Charge/Power "ON" LED illuminated push to test switch button for mandated code compliance test provides manual verification of the transfer circuit and LED fixtures

Output / Compatibility

- Works with or without an AC driver to convert new or existing LED fixtures into emergency lighting
- Provides constant power output to the load during emergency mode operation
- Suitable for >15W/24W systems with 20-50V output voltage

Electrical

- Universal 120-277VAC, 50/60Hz
- Long-life, Maintenance-free NiCad (EMD-15-CP-C) or LiFePO4 (EMD-24-CP-C) battery
- Provides a minimum of 90min of emergency operating time within operating temperatures. 24-hour maximum battery recharge time as per UL 924
- Charge/Power "ON" LED indicator light/ push to test switch for mandated code compliance test is included
- Input over current protection, output over voltage protection, output under current protection, output short circuit protection

Installation

- Suitable for top or in remote installation of an LED fixture
- The test button is easy to locate and provides manual verification of the transfer circuit and emergency lamps
- Can be remote mounted up to 20' (the remote distance cannot exceed 1/2 the distance from the driver to the LED load specified by the AC driver manufacturer)
- Remote charge/test button provides manual verification of the transfer circuit and emergency load

Testing & Compliance

- UL Listed for Dry/Damp Locations
- Meets UL 924 requirements
- CEC Title 20 compliant
- Suitable for field installation
- Operating temperatures: 0°C to 50°C (32°F to 122°F)

Model: _____ Date: _____
 Accessories: _____
 Job Name: _____ Type: _____



Warranty

Any component that fails due to a manufacturing defect is guaranteed for five years, with a five-year prorated warranty on the battery. The warranty does not cover physical damage, abuse or instances of uncontrollable natural forces. See the full Exitronix warranty document for detailed information. (Terms and conditions apply)

ORDERING INFORMATION Example: EMD-15-CP-C

Model	Description
EMD-15-CP-C	15W LED Constant Power Emergency LED Driver, 100-277VAC, NiCad, 15-50V Output, 12" Conduit Whip One End
EMD-24-CP-C	24W LED Constant Power Emergency LED Driver, 100-277VAC, LiFePO4, 15-50V Output, 12" Conduit Whip One End

Electrical Information

Model	Input Current (A)	Input Power (W)	Output Power	Output Voltage
EMD-15-CP-C	120mA max	8W max	15W	15-50V
EMD-24-CP-C	120mA max	8W max	24W	15-50V

DIMENSIONS

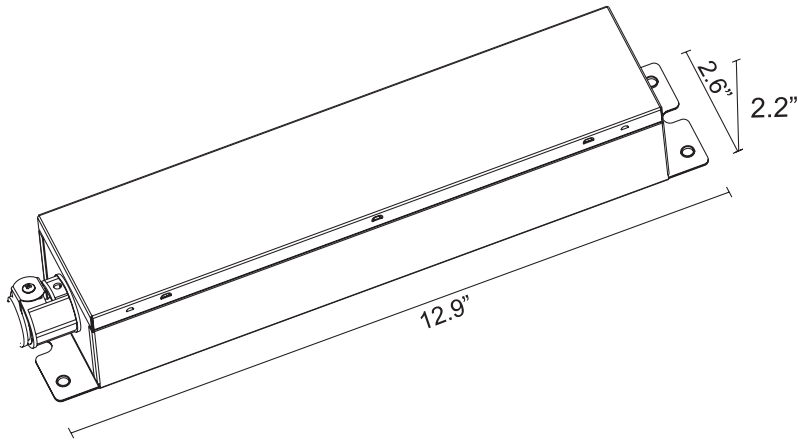

Please refer to instruction sheet for wiring diagram and additional information.