

**DESCRIPTION**

The ELB bollard applications include lighting pedestrian walkways, retail entryways, as well as lighting sidewalks around schools, medical complexes, retail entrances, park/ recreational paths, office buildings, and multi-family properties.

The ELB traditional louvered bollard utilizes long life LED technology to deliver uniform illumination, superior spacing and low glare due to its highly engineered optical design. The ELB offers durable extruded aluminum housing coated with a UV resistant powder finish to protect against the elements. It comes standard with 10kV surge protector and is secured with tamper-proof hardware. The LED engine is designed to deliver over 966 lumens.

This bollard is built to last, and is also offered in a High Abuse configuration built with a reinforced internal structure to withstand maximum abuse.

- Rugged, vandal resistant
- Pedestrian security in high traffic areas

All ELB bollards are assembled in the U.S.A.

**SPECIFICATIONS**

**Construction:**

- Die-cast aluminum dome top and louvers (3)
- Vandal resistant hardware (tool included)
- Available in a 36" and 42" height
- High Abuse model features an extruded aluminum internal impact beam interlocking with housing through the length of the unit for superior strength

**Optics/ LEDs:**

- Symmetric (360°) and Asymmetric (180°) distributions
- Polycarbonate lens shields LEDs
- Aimed LED modules minimize glare and maximize spacing
- 72 Mid-power LEDs deliver 966 lumens
- 3000K, 4000K and 5000K CCT
- L70 rated at > 60,000hrs at 40°C
- CRI 85

**Electrical:**

- Power supply rated Class A EMI rating
- Power supply with high power factor of 90% typical
- 0-10V dimming driver option
- Standard 10kV surge protectors included
- 347/480VAC dedicated driver available

**Installation:**

- One piece dome assembly for ease of installation and maintenance
- Countersunk tamper resistant hardware offering smooth housing surface
- Reversible housing for fool-proof installation
- High Abuse (HA) option: Tool-less assembly of internal impact beam
- Four (4) 3/8" anchor bolts, 5" standard bolt circle (included):  
Can accommodate a 4-1/2" to 5-1/4" bolt circle

**Options:**

- High Abuse configurations (HA), for added security
- Emergency Battery Backup (EM), UL924 Listed - provides 90 minutes of emergency illumination. (This option is rated for operation between 10°C to 40°C (50°F to 104°F))

**Accessories:**

- Anchor Bolt Kit and Template (ELB-BOLTKIT):  
Four (4) 3/8" x 6" bolts and nuts, sheet metal template

**Testing & Compliance:**

- UL listed for Wet Locations
- Ambient Temperature: -30°C to 40°C (-22°F to 104°F)
- Optional UL924 emergency egress

**Warranty:**

5 Year Warranty (Terms and Conditions Apply)

Model: \_\_\_\_\_ Date: \_\_\_\_\_  
 Accessories: \_\_\_\_\_  
 Job Name: \_\_\_\_\_ Type: \_\_\_\_\_



Specs At A Glance	
<b>Wattage (Nominal)</b>	18W, 35W
<b>Lumens (5000K)</b>	Up to 966 lm
<b>Efficacy (5000K)</b>	28 lm/w
<b>CCT</b>	3000K, 4000K, 5000K
<b>Input Voltage</b>	Voltage Sensing 120~277VAC 347/480VAC available
<b>Distribution</b>	Symmetric (360°), Asymmetric (180°)
<b>CRI</b>	85
<b>BUG Rating</b>	B1 U2 G1
<b>Installation</b>	4x 3/8" x 6" anchor bolts, 5" B.C.
<b>Ingress Protection</b>	UL Listed for Wet Locations
<b>Warranty</b>	5 Year Warranty
<b>Ambient Temp</b>	-30°C to 40°C (-22°F to 104°F)

\*Nominal length      \*\*Nominal wattage, tested at 5000K CCT  
**Note:** Environment and application will affect actual performance.  
 Typical values and 25°C used for testing.

## Ordering Information

Example: ELB-42-S-VS-4K-BL

Series	Height	Wattage/ Distribution	Voltage	CCT Temp.	Finish	Options (Factory Installed)
ELB <sup>1</sup>	36" = 36 Inches	A = 18 Watts, Asymmetric (180°)	VS = 120~277VAC Voltage Sensing (Std.)	3K = 3000K	BL = Black	HA <sup>5</sup> = High Abuse Configuration
	42 = 42 Inches	S = 35 Watts, Symmetric (360°)	HVS <sup>3</sup> = 347V/480V	4K = 4000K	BR = Bronze	EM <sup>6</sup> = UL924 Listed Emergency
				5K = 5000K	GR = Gray	Battery Backup
					SV = Silver	
					WH = White	
					CC <sup>4</sup> = Custom Color	
<b>Notes</b>						
<sup>1</sup> Comes standard with anchor bolt kit & template						
<sup>2</sup> Available while supplies last						
<sup>3</sup> 0-10V dimming not available						
<sup>4</sup> Consult factory						
<sup>5</sup> Only available in 42 inch height						
<sup>6</sup> 120/277VAC operation only, not compatible with HA option			<b>Accessories<sup>7</sup></b> (Field Installed)			
<sup>7</sup> Order on a separate line item			ELB-BOLTKIT = Anchor bolt kit consists of four (4) 3/8" x 6" x 6" bolts and nuts, sheet metal template			

## Dimensions

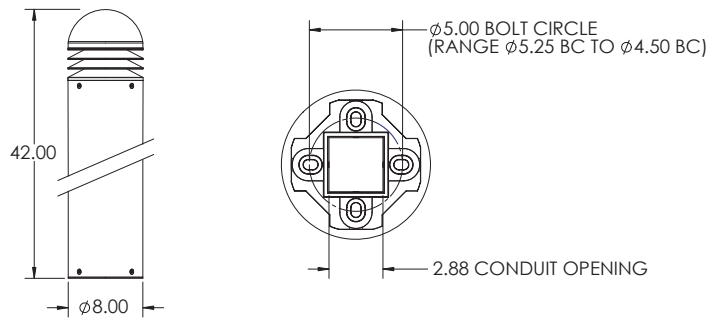

## Sample Photometry

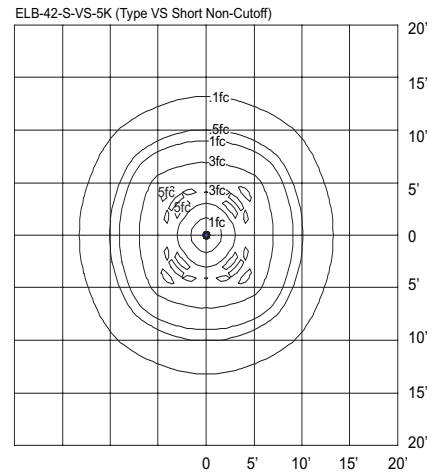

## Cross Section Head Detail View



## High Abuse Option Details

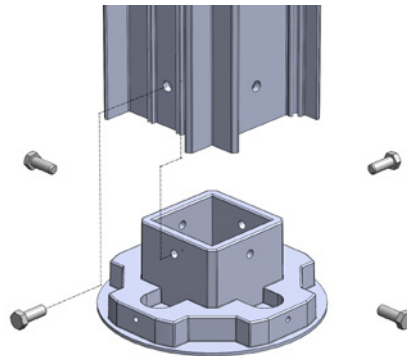

Internal Impact Beam Base Detail

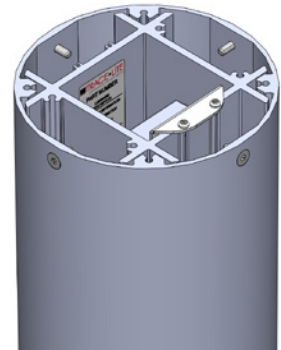

Internal Impact Beam Interlock with Housing