

The DMX-CV-DECODER-WP is a waterproof DMX512 decoder with IP67 rating, which enables the decoder to be use in outdoor and damp environments. Four channel output with constant current and constant voltage enables the DMX512 decoder to work with different types of LED lamps. It can be used to control DIM, CT, RGB, RGBW constant voltage lights and achieve 0-100% dimming or various lighting effects. Maximum output can be up to 5A per channel. DMX address can be set freely and shown on the numeric digital display.

FEATURES & BENEFITS:

- Waterproof DMX512 decoder with IP67 rating, suitable for outdoor and damp environments
- DMX signal output, complies with standard protocol DMX512, compatible with DMX masters from international suppliers
- DMX512 compliant control interface, DMX address can be set freely and shown on the digital numeric display
- Compatible with our DMX wall mounted controllers (single color, dual color, RGB) to achieve many different light dimming and controlling effects
- Input Voltage: 12-24VDC
- Input Current: Max. 20A
- Output Voltage: 4x(12-24)VDC
- Output Current: Max. 5A per channel, Max. 20A per 4 channels
- Output Power: (0-60...120)W per channel, Max. 480W per 4 channels
- Working Temperature: -20°C to 50°C (-4°F to 122°F)

PROTECTION:

- Short Circuit
- Over Temperature
- Over Current
- Auto Recovery

WARRANTY (Terms & Conditions Apply):

- Five Year Warranty
- Warranty is limited to the repair and/or replacement of this product. The warranty is covered by the Original Equipment Manufacturer. Details are available upon request.

Model: _____ Date: _____
 Accessories: _____
 Job Name: _____ Type: _____

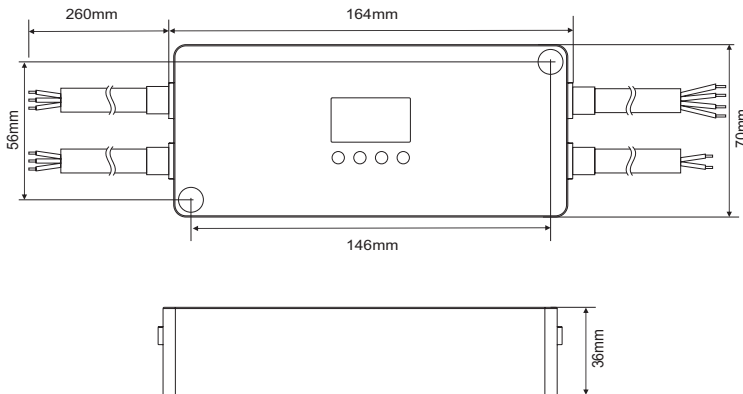

ORDERING INFORMATION

Example: DMX-CV-DECODER-WP

Model

DMX-CV-DECODER-WP = DMX512, 12-24VDC, 4CH 5A/CH, Max 480W, Constant Voltage, IP67 Rated

MAIN COMPONENTS

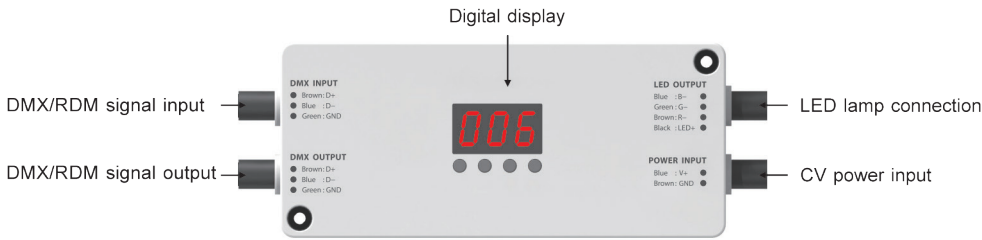

WIRING DIAGRAM

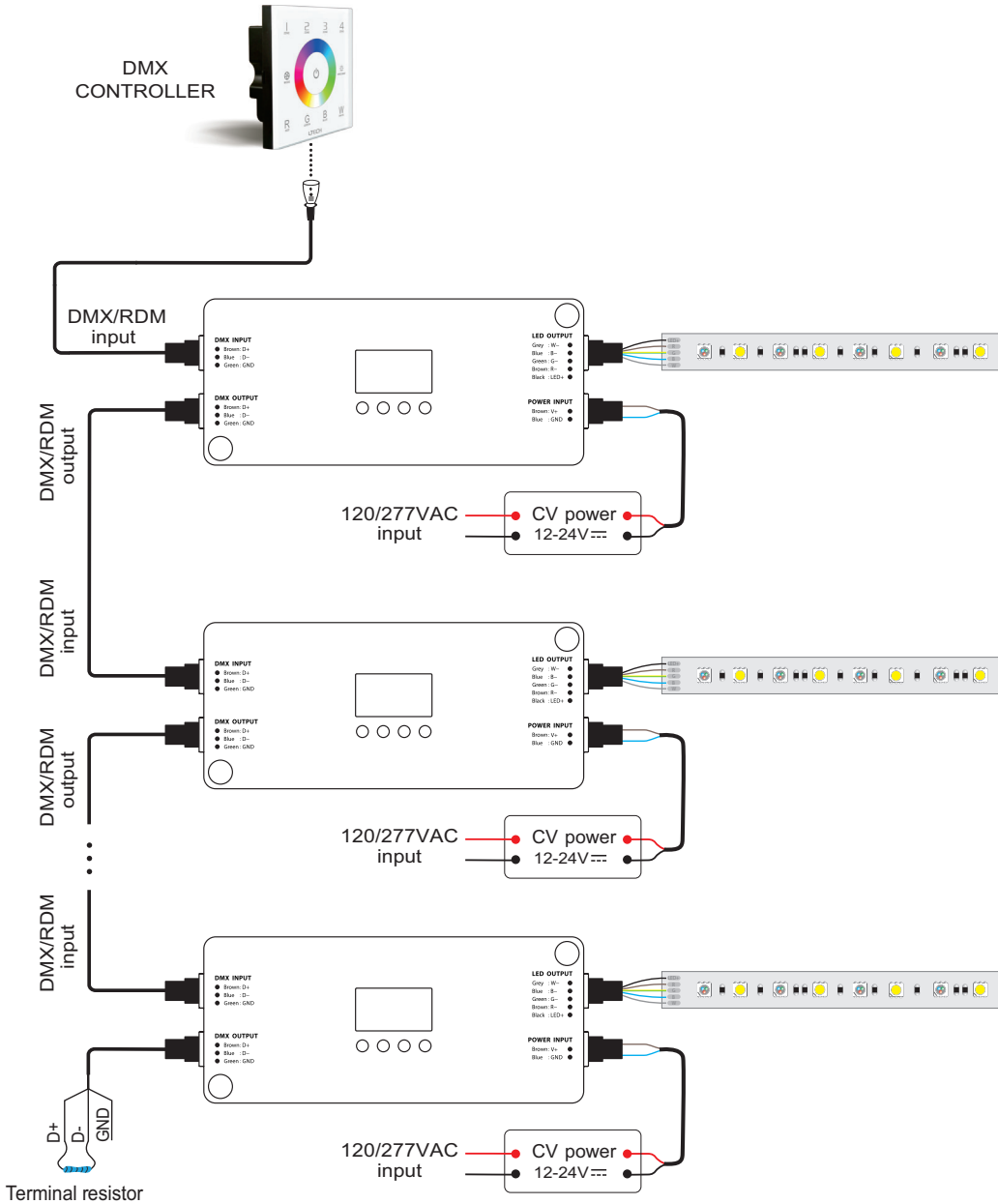

NOTE:

When more than 32 DMX decoders are connected, DMX signal amplifiers are needed and signal amplification should not be more than 5 times continuously. If you need to modify the parameter settings of connected DMX/RDM decoders that exceed 32, you can add 1 RDM signal amplifier. Or you can add 1-5 DMX signal amplifiers after completing the parameter settings.

If the recoil effect occurs because of long signal line or poor quality wires, please try to connect a 0.25W 90-120Ω terminal resistor at the end of each line.