

The LL50H Thermoplastic Emergency Lighting Units combine a low-profile, contemporary appearance with economy and dependability. It's compact, streamlined design features fully adjustable designer 5 watt halogen heads to compliment any environment. Constructed of of an injection-molded, 5VA flame retardant, high-impact, thermoplastic housing, this durable unit will provide years of reliable service.

FEATURES

- Compact, streamlined design
- Easy to install, snap together design
- UL94-5VA flame retardant thermoplastic components
- Fully-adjustable, high-intensity 5 watt MR16 halogen lamp
- AC lockout for ease of installation and installer protection
- Low voltage disconnect eliminates deep discharge
- Brown-out, short circuit and voltage surge protection
- Maintenance-free lead acid battery
- UL listed 90 minute emergency run time, 24 hour recharge time
- Ceiling or wall mount
- Optional Guardian Self-Test/ Self-Diagnostics (G2) available
- Standard finishes: White or Black
- 120/277V dual primary, 60Hz input
- Suitable for damp location

WARRANTY

Any component that fails due to manufacturers defect is guaranteed for 3 years with a separate 2 year pro-rated warranty on the battery. The warranty does not cover physical damage, abuse or acts of God. See the full Exitronix warranty document for detailed information.

Model: _____ Date: _____
 Accessories: _____
 Job Name: _____ Type: _____



ORDERING INFORMATION Example: LL50H-G2

Series	Finish	Options (Factory Installed)	Accessories ¹ (Field Installed)
LL50H = 6V, 5W Halogen Lamps	(Blank) = White BL = Black	G2 = Self-Test/Self-Diagnostics LC = 3" Line Cord	WG-1 = Wire Guard (Back Mount) WPV-2 = Wet Location/Vandal Guard (Back Mount) XG-90 = Poly Guard (Back Mount)

Notes

¹ Order as separate line item

CONSTRUCTION

Precision molded unit and lamp housings constructed of UV stable UL 924 V-0 flame retardant, corrosion proof thermoplastic. Units resist denting, peeling, scratching and corrosion. Not recommended for outdoor use. Tool-less access provided for easy maintenance, universal J-box mounting pattern and keyhole slots for simple installation.

ILLUMINATION

Two fully adjustable, attractive lamp heads allow for maximum light to be delivered to the path of egress. Emergency lights consist of 6V, 5W, MR-16 halogen lamps.

ELECTRICAL

Input

Dual-voltage input 120 or 277VAC @ 60Hz.

Sealed Lead Acid Battery – SLA

Exitronix sealed lead acid batteries are maintenance-free with a life expectancy of 5 years. Sealed lead acid batteries provide a relatively large power-to-weight ratio making them ideal for emergency applications. Lead Acid batteries are constructed of a series of plates stacked with separators designed to optimize the efficiency and prolong the life of the battery. Lead Acid batteries perform optimally in temperatures ranging from 15-40 degrees C.

Emergency

The LL50H will operate for a minimum of 90 minutes during a loss of power with a 24 hour maximum recharge time for the battery.

Brownout Circuit

The brownout circuit monitors the flow of AC current to the unit and triggers the emergency lighting system once a set reduction of AC power occurs. This dip in the voltage will cause many fixtures to extinguish causing loss of normal lighting even though a total power failure has not occurred.

Low Voltage Disconnect

When the battery's terminal voltage falls below predetermined levels, the low-voltage circuit disconnects the emergency lighting load. The disconnect remains in effect until normal power is restored, preventing deep battery discharge and improving the life of the battery. The disconnect will also automatically reconnect the load circuit once the battery voltage returns to a normal value after charging.

Solid-State Transfer

The unit features a solid-state switching transistor which eliminates damaged contacts or mechanical failures associated with relays. The switching circuit is designed to detect a loss of AC power and automatically energizes the lamps. Upon restoration of the AC voltage, the emergency lamps will switch off and the charger will automatically recharge the battery.

Overload and Short-Circuit Protection

The solid-state overload monitoring system in the DC circuit disconnects the lamp load from the battery should excessive wattage demands be made and automatically resets when the overload or short-circuit is removed. This overload current protective characteristic eliminates the need for fuses or circuit breakers for the DC load.

Test Button

Our easily located test button allows for manual verification of proper operation of the transfer circuit and emergency lamps.

INSTALLATION

A universal mounting pattern and rear keyhole slots are provided for wall mounting.

Damp Location Rated

Damp location rating ensures the fixture is designed to operate safely in outdoor locations that are protected from the direct elements. Damp location rated fixtures may be installed indoors. Products with damp location ratings are not designed to withstand constant or significant moisture or direct contact with water or steam.

Guardian Self-Test/Self-Diagnostics – (Option: G2)

The Guardian circuit continuously monitors the operating condition of the AC power, battery supply voltage, emergency lamp continuity and charging circuit.

The purpose of this option is to provide visual signaling in response to a fault at the EXIT sign battery and/or battery charger. If a failure is detected, visual status will occur immediately via the CHARGER LED and/or the BATTERY FAULT LED. The LEDs will stay illuminated until the fault is corrected.

The Guardian circuit also monitors the transfer circuit as well as performing automatic code compliant testing. The Guardian circuit will perform a 30 second discharge and self-test every 28-30 days. A 90 minute discharge and self-test is performed every 6 months.

CONFORMANCE TO CODES & STANDARDS

The LL50H Series is UL listed and meets or exceeds the following: UL 924, NEC requirements and NFPA 101.

DIMENSIONS

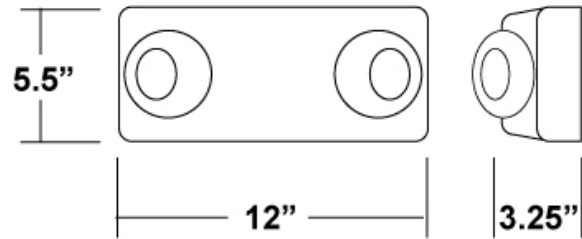

SAMPLE PHOTOMETRICS

Using multiple units mounted at a typical 7.5' delivers 24' center-to-center spacing on a 3' wide egress path.

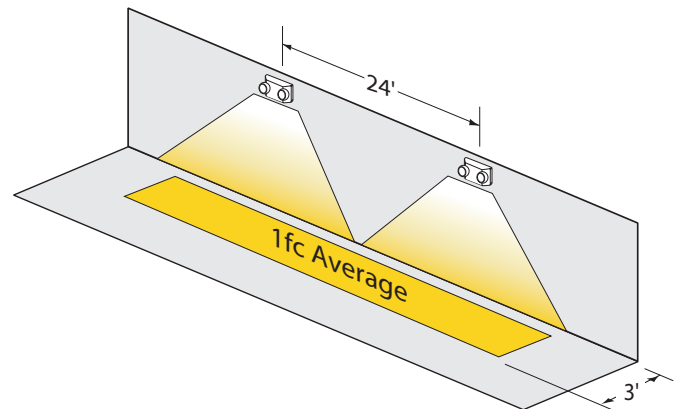

Using multiple units mounted at a typical 7.5' delivers 20' center-to-center spacing on a 6' wide egress path.

