

**DESCRIPTION**

TRACE\*LITE's new TLED220 series LED bullet floodlights feature new SSL light engines that provide high performance, efficient lighting with the flexibility and consistency of a traditional, bullet style floodlight. The TLED220 housings are constructed of die-cast aluminum with a UV resistant, thermoset polyester powder coat finish available in black, bronze or verde green, providing durable protection from environmental conditions, corrosion and the elements. The TLED220 series is suitable for mounting within 1.2M (4') of the ground. The LEDs and optics on the TLED220 series are protected by a high-impact tempered glass lenses.

**SPECIFICATIONS**

**Construction:**

The TLED220 series have precision designed cast aluminum housings with stainless steel hardware, tempered glass lenses, silicone gaskets and a UV resistant, thermoset polyester powder coated finish. The TLED220 is completely sealed with silicone gaskets. The TLED220 comes standard with a 1/2" threaded adjustable stem mount that satisfies many floodlight mounting applications and features angle marking for easy aiming.

**Optics:**

Our TLED220 series floodlights deliver exceptional quality of light, with a 4700K CCT a CRI of ≥75 and a projected color shift of less than 1%. The TLED220 utilize built-in visors and precision optical lenses that are specifically designed to distribute light forward in a tightly controlled beam pattern that puts light where it is needed in the most efficient way possible. The TLED220-11 delivers 778 lumens in a 3H x 3V distribution and the TLED220-15 delivers 1140 lumens in a 4H x 4V distribution, both of the TLED220 floodlights have an L70 of 50,000 hours.

**Electrical:**

The Cree XTE LEDs used in the TLED220 series are powered by constant current, high efficiency Class 2 LED driver with active power factor correction (0.92 typical), an IP66 rating and all around protection against over-voltage, over-temperature and short circuit conditions as well lightning protection. The TLED220 driver has a voltage sensing input of 120~277VAC 50/60Hz, a Class B EMI rating, and complies with UL8750 safety regulations and with ANSI/IEEE C62.41 Class A Operation. The TLED220 is suitable for operation in -22°F to 104°F (-30°C to 40°C) ambient conditions.

**Thermal Management:**

The LED light engine modules in the TLED220 series are each mounted directly to their own dedicated LEDLITE<sup>logic</sup> thermal heat sink. This configuration optimizes the thermal dissipation for the LEDs which in turn, makes possible the high efficacy, lumen output and longevity of the TLED220.

**Environmentally Friendly Design:**

TLED220 luminaires consume very little energy and provide long life in comparison to traditional lamp technologies. The TLED220 consumes only 11W or 15W, but the light output can conservatively be compared to a 60W or 100W halogen luminaire of similar design. Our manufacturing process utilizes no hazardous substances. The TLED220 provides a significant reduction in KW load and carbon emissions.

**Installation:**

The TLED220 series floodlight features a 1/2" adjustable, threaded stem mount that can be used for all bullet style floodlighting applications. Angle marking on the adjustable stem allow for accurate and easy aiming. Optional tamper-resistant hardware is available for applications where there is a high rate of vandalism, theft or in high traffic public spaces.

**Testing & Compliance:**

The reliability and performance of the TLED220 series are evaluated in accordance with the parameters outlined and reported by LM-79 and LM-80 documents. Photometric data is tested to IESNA LM-79-08 standard by an independent testing laboratory. Lumen maintenance, or L70, a measure of long term reliability, is determined for the light source, which consists of the LED and PSB sub-assembly as installed in the luminaire, using LM-80 in-situ thermal and reliability data as provided by the LED manufacturer in accordance with DOE/EPA standards.

Model: \_\_\_\_\_ Date: \_\_\_\_\_  
 Accessories: \_\_\_\_\_  
 Job Name: \_\_\_\_\_ Type: \_\_\_\_\_



Specs at a Glance		
<b>Wattage (Nominal)</b>	11W	15W
<b>Ingress Protection</b>	Suitable for Wet Locations	
<b>Lumens</b>	778	1140
<b>Efficacy</b>	69	74
<b>CCT</b>	4700K	
<b>Input Voltage</b>	120~277 Voltage Sensing	
<b>Optics</b>	Type 3H X 3V	Type 4H X 4V
<b>CRI</b>	≥75	
<b>Warranty</b>	5 Years	
<b>Ambient Temp</b>	-22°F to 104°F (-30°C to 40°C)	

**Warranty:**

Any component that fails due to manufacturer's defect is guaranteed for 5 years. The warranty does not cover physical damage, abuse or acts of God. Manufacturer reserves the right to charge for such repairs if deemed necessary.

## Fixture Performance

Part Number	Total System Watts	Initial Lumens	Lumens Per Watt (LPW)	L70 Hours @ 25°C
TLED220-11	11.2	778	69	50,000
TLED220-15	15.3	1140	74	50,000

NOTE: Lumen maintenance and life (part of LM-80 data) are per published information from primary LED suppliers and is based on design operation at their specified thermal management and electrical design parameters.

## Dimensions

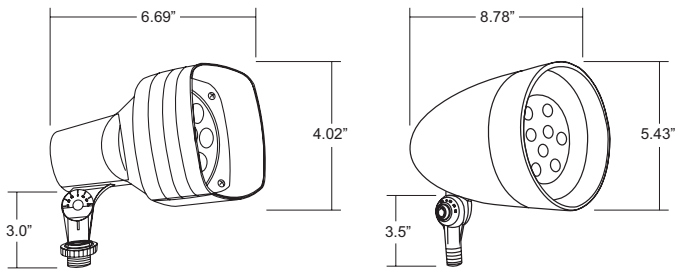

Approximate Weight: 1.5 to 2 lbs

## Sample Photometrics

TLED220-11 Mounted at 8' with 15° Tilt (Type 3H X 3V)

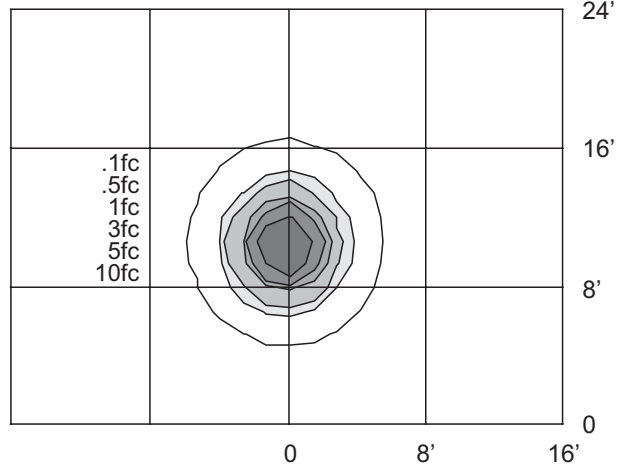

TLED220-15 Mounted at 8' with 15° Tilt (4H X 4V)

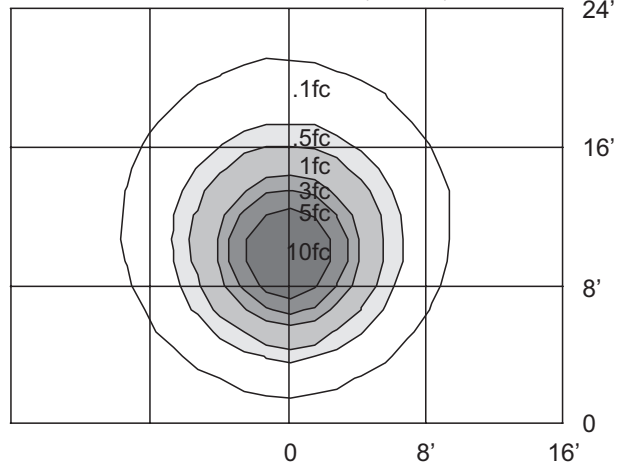

## Ordering Information

Example: TLED220-11-VS-VG-47K

Series	Total Watts (Nominal)	Input Voltage	Finish	Color Temperature
TLED220	11 = 11 Watts	VS = 120 ~ 277VAC (Voltage Sensing)	BL = Black	47K = 4700K CCT Lamp Color
	15 = 15 Watts		BR = Bronze	
			VG = Verde Green	

Specifications are subject to change without notice. Installation must be performed in accordance with Barron Lighting Group installation instructions.

10800259 08/15