

DESCRIPTION

The TLED101 series mini wallpack features a durable, vandal resistant, injection molded bronze polycarbonate enclosure combined with a high performance LED light source that makes it a durable and efficient choice. Constructed of polycarbonate with a die-cast aluminum base plate, the TLED101 is fully sealed and gasketed, and is UL Listed for Wet Locations. Available with a 13 watt COB LED light engine, the TLED101 provides an ideal light distribution and has a wide spectrum of applications including schools, office complexes, light commercial, apartments and recreational facilities.

SPECIFICATIONS

Construction:

Precision molded polycarbonate housing is mounted to a die-cast aluminum base plate that provides superior heat dissipation while still maintaining an economical luminaire with durable performance. Fixture is completely sealed and gasketed with corrosion-resistant stainless steel captive fasteners. The LED light engine is protected by a high impact, UV stabilized polycarbonate prismatic refractor.

Optics:

TLED101 series delivers exceptional light quality, efficiency and light distribution. The 13 watt COB LED light engine powered by a constant current control driver provides a 50,000 hour rated life, 70% lumen maintenance, 5000K CCT and a CRI of ≥ 70 .

Electrical:

The TLED101 series operates from 120-277V 50/60Hz with an auto-ranging voltage controlled circuit and simple two (2) wire input. The TLED101 is suitable for operation in -22°F to 104°F (-30°C to 40°C) ambient conditions. Comes standard with 120VAC photocontrol. Optional transient surge protection and 277VAC photocontrol are available.

Thermal Management:

LED light engines and drivers are securely mounted directly to an aluminum heat sink optimizing thermal management. LEDLITE/logic heat sinking technology moves heat away from the LEDs maximizing system performance and delivering 50,000+ hour life with >70% lumen maintenance.

Environmentally Friendly Design:

TLED101 luminaires consume very little energy and provide long life in comparison to traditional lamp technologies. The LED light engines emit an extremely low UV and minimal heat. The compact design allows for the use of fewer materials, resulting in less overall waste.

Installation:

The TLED101 series is ideal for mounting to any vertical surface and easily attaches to a 3" or 4" J-box. The TLED101 can also be surface mounted using the 1/2" conduit entry point at the bottom of the housing.

Transient Protection System (Option: TP):

The LEDLITE/logic optional transient protection device is designed to be used in conjunction with our LED drivers. The "-TP" option utilizes a 3-leaded device that protects Line-Ground, Line-Neutral, and Neutral-Ground in accordance with IEEE/ANSI C62.41.2 guidelines. The surge current rating of the "-TP" option is 10,000 amps.

Photocontrol:

120VAC button style photocontrol included standard provides dusk-to-dawn security lighting. Optional field installed 277VAC photocontrol is available. Photocontrol voltage must match input voltage.

Testing & Compliance:

The reliability and performance of the TLED101 is evaluated in accordance with the parameters outlined and reported by LM-79 and LM-80 documents. Photometric data is tested to IESNA LM-79-08 standard by an independent testing laboratory. Lumen maintenance, or L70, a measure of long term reliability, is determined for the light source, which consists of the LED and PSB sub-assembly as installed in the luminaire, using LM-80 in-situ thermal and reliability data as provided by the LED manufacturer in accordance with DOE/EPA standards.

Warranty:

Any component that fails due to manufacturer's defect is guaranteed for 5 years. The warranty does not cover physical damage, abuse or acts of God. Manufacturer reserves the right to charge for such repairs if deemed necessary.

Model: _____ Date: _____
 Accessories: _____
 Job Name: _____ Type: _____



Specs at a Glance	
Wattage (Nominal)	13W
Ingress Protection	Suitable for Wet Locations
Lumens (5000K)	770
Efficacy (5000K)	59
CCT	5000K
Input Voltage	120/277VAC
Optics	Type IV Short
CRI	≥ 70
Warranty	5 Years
Ambient Temp	-22°F to 104°F (-30°C to 40°C)

Fixture Performance

Part Number	Lumens	Lumens Per Watt (LPW)	Nominal LED Wattage	BUG Rating
TLED101-13	770	59	13	B0-U3-G1

NOTE: Lumen maintenance and life (part of LM-80 data) are per published information from primary LED suppliers and is based on design operation at their specified thermal management and electrical design parameters.

Dimensions

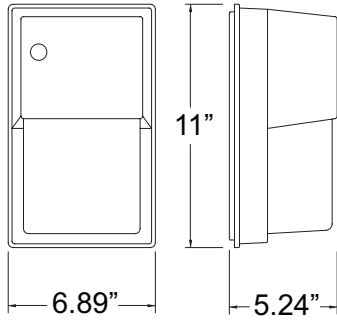

Approximate Weight: 4 lbs.

Sample Photometrics

TLED101-13 Mounted at 10' (Type IV Short Non-Cutoff)
Horizontal Spacing Criteria: 3.42

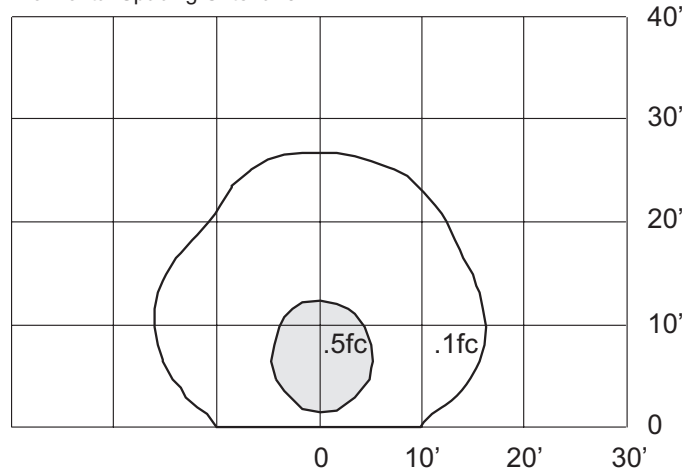

Ordering Information

Example: TLED101-13-DT-5K-TP

Series	Total Watts (Nominal)	Input Voltage	CCT	Options (Factory Installed)	Accessories ¹ (Field Installed)
TLED101	13 = 13 Watts	DT = 120/277VAC	5K = 5000K	TP = Transient Protection System	PC2 = 277VAC Photocontrol

Notes

¹ Order as separate line item