

DESCRIPTION

The TLED-SC-G sensor canopy utilizes TRACE*LITE's successful LED surface mount canopy design and brings it to a new level of performance and efficiency by the addition of the factory installed Wattstopper FSP-211 Digital High/Low passive infrared sensor. The sensor allows for fully adjustable high and low dimmed light levels based on motion, adjustable time delay, cut off delay and is controlled via the 0-10V dimming driver in the fixture. It also includes an integrated photocell to measure ambient light levels. This sensor is provided with an FSP-L2 lens that was selected for its proven design and ability to provide maximum coverage at an 8ft mounting height. Other lenses are available for multiple mounting heights. Contact factory for details. The TLED-SC-G series conforms to the Title24 requirements in regards to dimming and control of light fixtures.

The TLED-SC-G extends the low profile form factor of the complete line by integrating the Wattstopper Occupancy and Daylight sensor on one side of the fixture, ensuring the ease of installation our LED canopy is known for. Our next generation high performance LED light engines feature our superior thermal management that make the entire family an attractive, energy saving choice. Constructed of die formed and welded aluminum, the TLED canopy series family has been engineered to deliver optimum optical performance and lamp longevity. The attractive and durable housings have a UV resistant, powder coated finish to protect against the elements and are ETL Listed for Wet Locations. Our TLED series canopies incorporate contractor friendly features that allow for ease of installation in a variety of applications and can be installed by a single person. Available with five (5) different LED light engine configurations with 21, 28, 41 or 55 total system watts and approximate delivered lumen outputs of 1907, 2817, 4119 or 5712. The TLED-SC-G series canopies provide an energy saving solution to a wide spectrum of applications including, but not limited to security lighting in schools, office complexes, light commercial development, apartments, parking garages, entryways, and stairwells. The TLED series canopies are DesignLights Consortium™ (DLC) qualified and meet or exceed the efficacy requirements for various rebate programs across the country.

SPECIFICATIONS

Construction:

Precision die formed aluminum housings feature clean architectural lines with ample, integral mounting space for future accessories. The TLED canopy series family's most important construction feature is their integral thermal management. The housing is fabricated using 1/8" aluminum plate, which not only provides strength and durability but also acts as a substantial heat sink and allows for optimum performance and durability of the LED light engine without sacrificing design aesthetics or increasing the outside dimensions of the housing. LEDLITE^{logic} heat sinking technology moves heat away from the LEDs by taking advantage of thermal convection dynamic properties and maximizing system performance that delivers up to a 190,000 hour life with 70% lumen maintenance. The TLED canopy series family is ETL Listed for Wet Locations, and incorporates a UV resistant, long lasting, polyester based powder coat finish.

Optics:

The TLED canopy series family of luminaires deliver exceptional light quality and efficiency with a garage optic design that provides excellent Type VS distribution. Our garage optic provides more lumens in the 60° to 80° zone, which satisfies the DLC requirements for parking garage luminaires. The stabilized optical PMMA lenses are specifically designed to distribute light where it is needed in the most efficient way possible making it the ideal luminaire for high efficiency applications.

Electrical:

A choice of five (5) performance levels are available in the TLED canopy series family offering LED light engines with either 18, 24, 36 or 48 LEDs, drawing 21, 28, 41 or 55 total watts and providing approximately 1907, 2817, 4119 or 5712 initial delivered lumens, respectively. See chart on page 2 for complete performance figures. The available LED light engine wattages are powered by 0-10V dimmable, constant current control drivers and provide up to a 190,000 hour rated life with 70% lumen maintenance, a 4700K CCT, and a CRI of ≥72. All drivers are Class 2 power supplies with input voltage range of 120VAC to 277VAC, providing a Class A EMI rating and a high power factor of ≥0.90. The TLED series canopies are suitable for operation in -40°F to 104°F (-40°C to 40°C) ambient conditions.

Thermal Management:

LEDLITE^{logic} heat sinking technology moves heat away from the LEDs by taking advantage of thermal convection dynamic properties and maximizing system performance that delivers up to a 190,000 hour life with 70% lumen maintenance.

Environmentally Friendly Design:

TLED-SC-G canopy series luminaires consume very little energy and provide long life in comparison to traditional lamp technologies. The TLED-SC-G is RoHS (Restriction of Hazardous Substances) compliant and provides a significant reduction in KW load and carbon emissions.

Installation:

The TLED series canopies can be installed and wired by a single person. The base plate easily attaches to a 3" or 4" J-box, and the fixture housing is attached to the base plate by four (4) captive fasteners. The TLED-SC can be surface mounted to a recessed J-box or pendant mounted using a standard 1/2" downrod & hardware (supplied by others).

Model: _____ Date: _____
 Accessories: _____
 Job Name: _____ Type: _____



Specs at a Glance				
	18 LED	24 LED	36 LED	48 LED
Wattage (Nominal)	21W	28W	41W	55W
Ingress Protection	UL Listed for Wet Locations			
Lumens (lm)	1907	2817	4119	5712
Efficacy (LPW)	92	101	101	104
CCT	4700K			
Input Voltage	120-277 Voltage Sensing			
Optics	Performance Optic - Type V Very Short			
CRI	≥72			
Warranty	5 Years			
Ambient Temp	-40°F to 104°F (-40°C to 40°C)			

Transient Protection System (Option: TP):

The LEDLITE^{logic} optional transient protection device is designed to be used in conjunction with our LED drivers. The "-TP" option utilizes a 3-leaded device that protects Line-Ground, Line-Neutral, and Neutral-Ground in accordance with IEEE/ANSI C62.41.2 guidelines. The surge current rating of the "-TP" option is 10,000 amps.

Testing & Compliance:

The reliability and performance of the TLED canopy series luminaires are evaluated in accordance with the parameters outlined and reported by LM-79 and LM-80 documents. Photometric data is tested to IESNA LM-79-08 standard by an independent testing laboratory. Lumen maintenance, or L70, a measure of long term reliability, is determined for the light source, which consists of the LED and PSB sub-assembly as installed in the luminaire, using LM-80 in-situ thermal and reliability data as provided by the LED manufacturer in accordance with DOE/EPA standards. DesignLights Consortium® (DLC) qualified luminaire (check QPL for specific models).

Listing:

The TLED-SC-G is ETL certified under UL1598 specifications and listed for wet locations.

Warranty:

Any component that fails due to manufacturer's defect is guaranteed for 5 years. The warranty does not cover physical damage, abuse or acts of God. Manufacturer reserves the right to charge for such repairs if deemed necessary.

Fixture Performance

Part Number	Total System Watts	Initial Delivered Lumens	Lumens per Watt (LPW)	BUG Ratings
TLED-SC-18-VS-G	21	1907	92	B2-U0-G1
TLED-SC-24-VS-G	28	2817	101	B2-U0-G1
TLED-SC-36-VS-G	41	4119	101	B3-U0-G1
TLED-SC-48-VS-G	55	5712	104	B3-U0-G1

NOTE: Lumen maintenance and life (part of LM-80 data) are per published information from primary LED suppliers and is based on design operation at their specified thermal management and electrical design parameters.

Dimensions

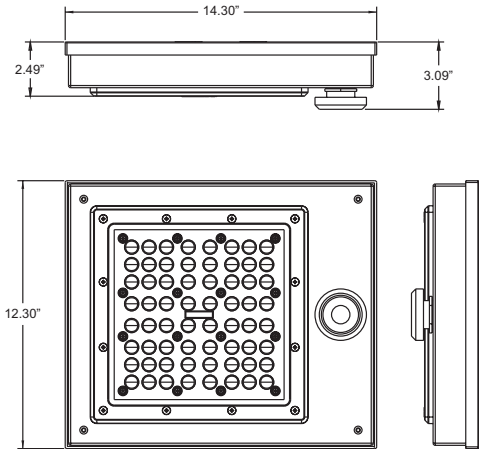

Approximate Weight: 14 lbs.

Sample Photometrics

TLED-SC-48-VS-G Mounted at 10' (Type V Short)
Horizontal Spacing Criteria: 2.86

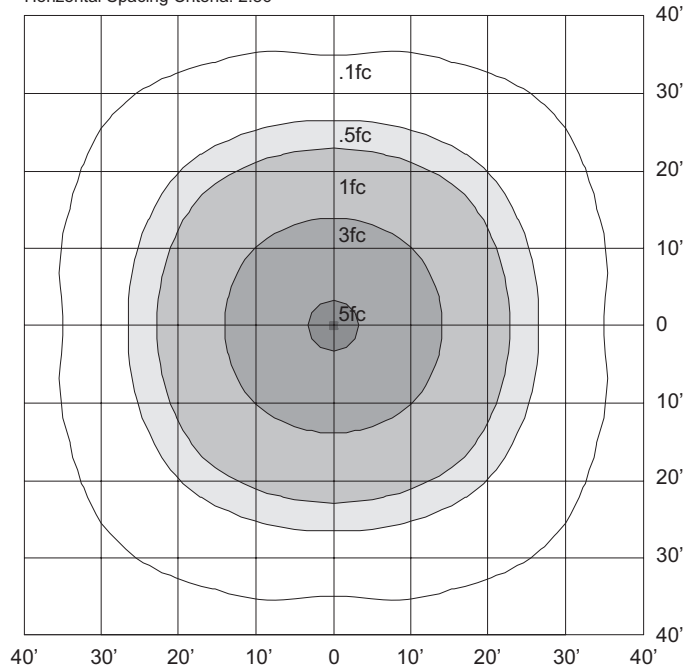

Ordering Information

Example: TLED-SC-24-VS-G-WW

Series	# of LEDs	Input Voltage	Optics	Finish (Housing/Trim)	Options (Factory Installed)
TLED-SC = Standard Canopy	18 = 18 LEDs	VS = 120~277VAC (Voltage Sensing)	G = Garage Optics	WW = White/White	TP = Transient Protection System
	24 = 24 LEDs				
	36 = 36 LEDs				
	48 = 48 LEDs				

Digital High/Low Infrared Sensor (Option: SC)

The TLED-SC sensor canopy utilizes TRACE*LITE's successful LED surface mount canopy design and brings it to a new level of performance and efficiency by the addition of the factory installed Wattstopper FSP-211 Digital High/Low passive infrared sensor. The sensor allows for fully adjustable high and low dimmed light levels based on motion, adjustable time delay, cut off delay and is controlled via the 0-10V dimming driver in the fixture. It also includes an integrated photocell to measure ambient light levels. This sensor is provided with an FSP-L2 lens that was selected for its proven design and ability to provide maximum coverage at an 8ft mounting height. Other lenses are available for multiple mounting heights. Contact factory for details.

The TLED-SC series conform to the Title24 requirements in regards to dimming and control of light fixtures.

Default Settings for Sensor:

High Mode: 0-10V; **default 10V**
 Low mode: Off, 0-9.8V; **default 1V**
 Time Delay: 30sec., 5-30min.; **default 5min.**
 Cut off delay: none, 1-60min. 1-5hrs.; **default 1hr.**
 Sensitivity: none, low, med, max; **default max**
 Setpoint: none, 1-250 fc, auto; **default disabled**
 Ramp up time: none, 1-60 sec.; **default disabled**
 Fade down time: none, 1-60sec.; **default disabled**

NOTE: Wireless programmable handheld unit to change settings is available through Wattstopper (FSIR-100)

Sensor Side and Top Coverage Pattern

L2 lens provides maximum coverage at an 8ft mounting height. Other lenses are available for multiple mounting heights. Contact factory for details.

