

Model Number:

Approvals:

Accessories:

Job:

Type:

DESCRIPTION

The Trace-lite TL119 Series is an attractive, semi-cutoff wallpack that is ideal for parking areas, entrances, walkways, underpasses, loading docks, and recreation areas.

SPECIFICATIONS**Construction:**

The Trace-lite TL119 Series features a durable, die-cast aluminum housing with an architectural bronze powder coated finish. Enclosure is fully sealed and gasketed, and is Wet Location Listed for outdoor use. Enclosure and hardware are corrosion resistant. The TL119 features an internal, anodized aluminum reflector which provides ideal light distribution, and the lamp(s) are protected by a vandal-resistant, borosilicate glass prismatic refractor.

Lamps & Ballasts

High Pressure Sodium: B17 type lamps from 35 to 150 watts, utilizing a medium base, glazed porcelain socket pulse rated for 4KV with either a R-NPF, HX-HPF or CWA type ballast rated for a minimum operating temperature of -30°C (-22°F).

Metal Halide: BD17 type lamps from 50 to 100 watts, utilizing a medium base, glazed porcelain socket pulse rated for 4KV with an HX-HPF ballast rated for a minimum operating temperature of -30°C (-22°F).

Pulse Start Metal Halide: BD17 type lamps from 150 watts, utilizing a medium base, glazed porcelain socket pulse rated for 4KV with a CWA ballast rated for a minimum operating temperature of -30°C (-22°F).

Installation:

The Trace-lite TL119 Series is ideal for mounting to any vertical surface and features a hinged design for easy access to internal components. Unit can be wired to a 4" junction box or surface mounted using 1/2" NPS conduit entry points.

ARRA - Buy America (Option: USA):

Fixture series may be built to comply with the American Recovery and Reinvestment Act of 2009 (ARRA) requirements and Buy American provisions - call factory for details.

Photocontrol (Accessory: PC):

Optional field-installed photocontrol provides dusk-till-dawn security. Input voltage must be specified to match fixture input voltage.

Listing:

The TL119 is CSA listed for wet locations.

Warranty:

Any housing component that fails due to manufacturer's defect is guaranteed for two years from time of shipment. Ballasts, Capacitors, and Ignitors are warranted for one year from time of shipment. Warranty does not apply to damages caused by improper installation, abuse, fire or acts of God. Lamp is not covered by manufacturer's warranty.



SPECIFICATIONS ARE SUBJECT
TO CHANGE WITHOUT NOTICE

SAMPLE PHOTOMETRICS

TL119-PSMH-150 Mounted at 10'

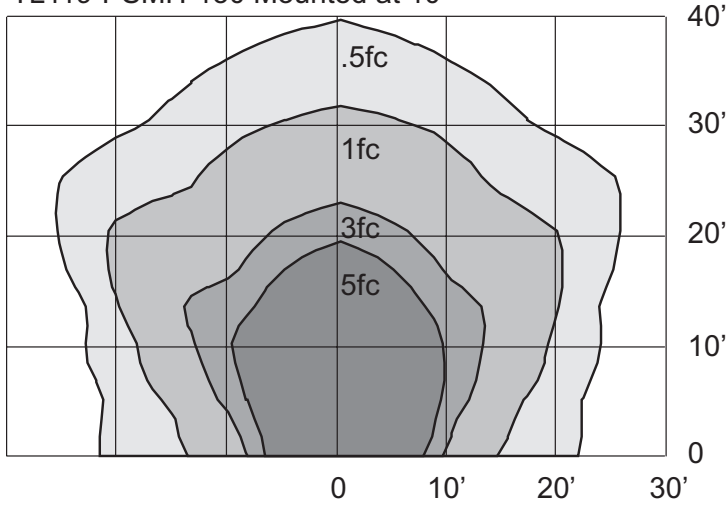

DIMENSIONS

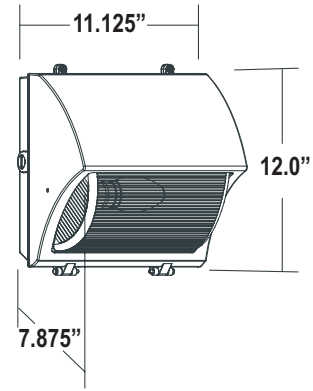

Approximate Weight: 15 lbs.

Footcandle Correction

Multiply factors times the footcandle values for changes in lamp type.

Lamps	50W MH	70W MH	100W MH	150W PSMH	150W HPS
Factor	.24	.41	.68	1.00	1.20

ORDERING INFORMATION

Example: TL119-HPS-100-MT-SZ277-USA

Series	Lamp Type	Lamp Wattage	Input Voltage	Options (Factory Installed)
TL119	HPS = High Pressure Sodium	High Pressure Sodium	120 ¹ = 120VAC	SZXXX ⁴ = Single Line Side Fuse (120 or 277VAC)
	MH = Metal Halide	35 = 35 Watts	MT ² = 120/208/240/277VAC	DZXXX ⁴ = Double Line Side Fuse (208, 240 or 480VAC)
	PSMH = Pulse Start Metal Halide	50 = 50 Watts	480 ³ = 480VAC	USA = Meets Buy America Requirements
		70 = 70 Watts		
		100 = 100 Watts		
		150 = 150 Watts		
Notes		Metal Halide		Accessories⁵ (Field Installed)
¹ HPS only		50 = 50 Watts		PC1 = 120VAC Photocontrol
² Not available on 35-50 watt HPS		70 = 70 Watts		PC2 = 208-277VAC Photocontrol
³ 100-150 watt only		100 = 100 Watts		WG119 = Wire Guard
⁴ Specify voltage		Pulse Start Metal Halide		RL119 = Replacement Lens
⁵ Order as separate line item		150 = 150 Watts		

